

---

# d<sup>i</sup>Tower

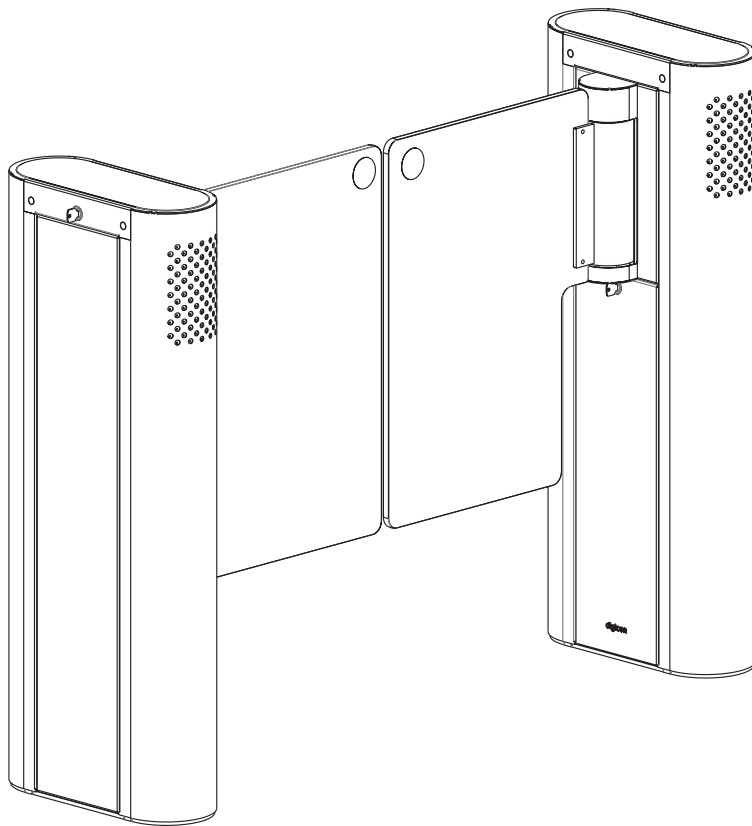

**digicon**

Copyright - Digicon S.A. Controle Eletrônico para Mecânica

All rights reserved. No part of this publication may be reproduced, transmitted, transcribed, stored in a retrieval system, or translated into any language or computer language by any electronic, magnetic, optical, chemical, manual, or other means without the express written permission of Digicon S.A.

Code: 069.31.221

Version: 12 - english

This manual was prepared by: Digicon S.A. Controle Eletrônico para Mecânica  
Setor de Documentação - EDS



Revision	Date	Revision	History
12	10/10/2024	• Fabio Sidiomar	• New dTower manual

## Index

1. Introduction.....	6
2. Safety Instructions.....	7
2.1 Symbols.....	7
2.2 Terminology.....	8
2.3 Risks.....	8
2.3.1 Risk of Unpacking the Equipment.....	9
2.3.2 Risks During Equipment Installation:.....	9
2.3.3 Risks in Equipment Use.....	10
2.3.4 Risks in Equipment Maintenance.....	11
2.3.5 Risks During the Equipment Cleaning Process.....	11
3.Features of the dTower.....	12
3.1 dTower Pictograms:.....	13
3.1 Functional Description.....	15
4. Unpacking, Mounting, and Electrical Connection.....	17
4.1 Unpacking the Package.....	17
4.1.1 Packaging Dimensions:.....	18
4.1.2 Necessary Tools:.....	18
4.1.3 Key Parts of the Product.....	21
4.2 Fixation.....	22
4.2.1 Before installing the dTower, check:.....	22
5. Installation and Assembly.....	23
5.1 Unpacking.....	23
5.2 Pre-Installation.....	23
5.3 Floor fixation.....	25
5.4 Fixing the doors.....	27
5.4.1 Labels.....	28
5.5 Access to the dTower after assembly.....	29
6. Electrical connection.....	30

6.1 Interconnection of equipment.....	30
6.2 Connection to the power grid: .....	32
6.3 Connection of control signals .....	33
6.4 dTower Operation.....	37
6.4.1 Control board.....	37
6.4.2 Functionalities.....	38
6.4.2.1 Configurable Functions (via inputs).....	43
6.4.2.2 Configurable Functions (via DS1) .....	45
7. Technical specifications .....	50
7.1 Dimensions .....	50
7.2 Other Information .....	51
8. Troubleshooting .....	52
9. Preventive Maintenance .....	55
9.1 Preventive Actions Table:.....	55
10. Cleaning .....	57
10.1 Maintenance and conservation of stainless steel: .....	57
10.2 Maintenance and conservation of polycarbonate (doors): .....	59
11. Warranty and Technical Support.....	61
12. Important Information .....	62
NOTES: .....	63

## **1. Introduction**

When innovation meets robustness and design meets reliability, you find the best access control solution. Digicon presents a solution carefully crafted to bring innovation, quality, and design to the access control market. The dTower was born as a result of an intense research process on global trends and rigorous engineering work.

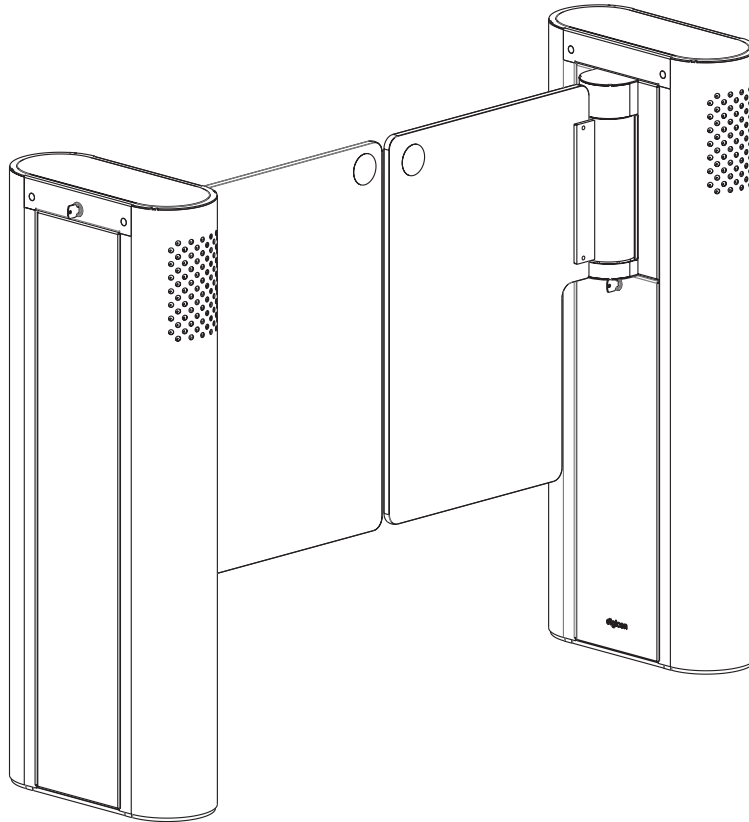



## **2. Safety Instructions**

### **2.1 Symbols**

You will find the symbols below in the Product Manual. They indicate important warnings regarding Attention and Caution related to the safety, installation, operation, and maintenance of the equipment.

 **CAUTION!:** Describes something important that must be known by the qualified technical professional and the user.

 **WARNING - RISK OF INJURY!:** Describes hazardous situations that may lead to injuries and/or harm.

 **DANGER - RISK OF DEATH!:** Describes high-risk situations that may lead to death. These cases are related to interaction with the internal parts of the equipment, and it is recommended to use a **qualified technical professional**.

**Read and keep the instructions in this manual:** Read and keep this Product Manual for future reference. Carefully read all safety, unpacking, installation, operation, and maintenance instructions before operating this equipment.

**Follow the instructions and caution warnings:** Follow all installation, operation/ use, and maintenance instructions. Pay attention to all cautionary warnings, care instructions, and precautions in the operating instructions, as well as those attached to this equipment. The caution and care warnings are essential for the protection of the user and the qualified technical professional, as well as for the longevity of the equipment.

## 2.2 Terminology

The terms defined below are used in this document. The definitions provided are based on those found in safety standards:

Qualified Technical Professional: The term qualified technical professional applies to individuals trained and certified by Digicon who are authorized to install, replace, or provide technical assistance for their equipment. It is recommended that the **qualified technical professional** use their experience, technical skills, and best practices to avoid potential injuries to themselves and others due to risks present in restricted access areas. This approach should be adopted to mitigate risks and also to extend the equipment's lifespan.

 **ATTENTION!** Installation and/or maintenance performed by an unqualified technician may void the equipment's warranty.

User: The term "user" applies to individuals who are not qualified technical professionals and use the equipment.

## 2.3 Risks

The following safety information and warnings are provided to protect you from injury and prevent damage to the equipment.

Children and individuals who require assistance may be unable to assess the risks associated with using the equipment, potentially injuring themselves or putting themselves in life-threatening situations.

Special attention should also be given to animals that may be near the equipment.



Below, we will mention risks that should be considered in various situations:

### 2.3.1 Risk of Unpacking the Equipment



#### **ATTENTION!:**

- Always use the appropriate tools.
- Always use the necessary PPE (gloves, shoes, and protective glasses).



#### **WARNING! - RISK OF INJURY/DAMAGE!**

- Handle the equipment packaging with care.
- The packaging is heavy, be careful to prevent it from tipping over, as it could cause injury and damage to the equipment.
- The packaging is heavy, ensure it does not tip over, as it may cause injury and damage to the equipment.
- Be cautious with your hands and feet when removing the equipment from the packaging and placing it in the installation location.

### 2.3.2 Risks During Equipment Installation:



#### **ATTENTION!:**

- All installation steps must be carried out by a qualified technical professional, and appropriate tools and PPE must be used.

Before turning on the power, perform a detailed inspection of the installation.



#### **WARNING! - RISK OF INJURY/DAMAGE!**

- warning: Be careful when positioning this equipment in the installation location, as its size and weight may cause injury.
- During the initial operation phase, the doors may move. Keep the passage area clear to avoid collisions with objects and people.

 **WARNING: RISK OF DEATH!**

- This equipment operates with dangerous electrical voltages. To avoid the risk of electric shock, installation must be performed exclusively by a **qualified technical professional**.
- Before performing any procedure, ensure that the electrical power is turned off.

### 2.3.3 Risks in Equipment Use

 **CAUTION - RISK OF INJURY!:**

- Caution, this is an access control device; the doors may close in certain situations. The impact of the doors on the human body can cause bruises and even fractures.

 **CAUTION - RISK OF DEATH!**

Children and individuals requiring assistance must be constantly supervised, as they may be unable to assess the risks associated with using the equipment, potentially injuring themselves or putting themselves in life-threatening situations.

### 2.3.4 Risks in Equipment Maintenance

 **ATTENTION!**

All maintenance steps must be carried out by a qualified technical professional, using appropriate tools and PPE.

 **CAUTION - RISK OF INJURY!**

- Be cautious with hands and fingers during maintenance, as the door movement mechanisms may cause serious injuries.

 **CAUTION - RISK OF DEATH!**

- The equipment has glass parts. Always wear protective glasses.
- Before performing any procedure, make sure the electrical power is turned off;
- Failure to comply with the above recommendations may result in serious injury or death.

### 2.3.5 Risks During the Equipment Cleaning Process

 **ATTENTION!**

- Use the necessary PPE (gloves and protective glasses) throughout the cleaning process.

 **CAUTION - RISK OF INJURY!**

Be cautious during the cleaning process, as the doors may close in certain situations. The impact of the doors on the human body can cause bruises and even fractures.

- In the cleaning section of this manual, the appropriate products for cleaning the equipment are listed. Using the correct products protects both the equipment and the skin of the person performing the cleaning.

### **3.Features of the dTower**

1. Innovative design, following the dGate and dFlow lines.
2. Robust solution with a motorized system and proprietary control technology.
3. Reinforced structure for floor mounting.
4. Available in stainless steel and powder-coated carbon steel.
5. Available with 12mm polycarbonate or glass doors
6. Configurable door movement speed.
7. Features operational pictogram (top) – access granted/blocked.
8. Features directional pictograms (front) in both directions.
9. Includes configurable acoustic signal (beep) for access control.
10. Bidirectional door movement.
11. Inputs for controlling door opening or closing activation.
12. Optional card collector safe.
13. Allows installation of proximity readers at the ends.
14. Available with 2D barcode reader option.
15. Easy integration with available access controllers on the market.
16. Easy interconnection between “R” and “T” locks.
17. Configurable passage time control modes.
18. Configurable security mode.
19. Has an IP42 protection rating.

### 3.1 dTower Pictograms:

The dTower has two pictograms: orientation and operation.

#### a) Operational Pictogram (Top):

The operational pictogram is installed on the top part of the equipment and is represented by a sequence of LEDs in two colors, depending on the direction of the flow of operation and the validation group, if applicable.

Flashing red LEDs or LEDs flowing only in the opposite direction indicate that passage is not allowed.

Green LEDs flowing in the direction of passage indicate that passage is free.

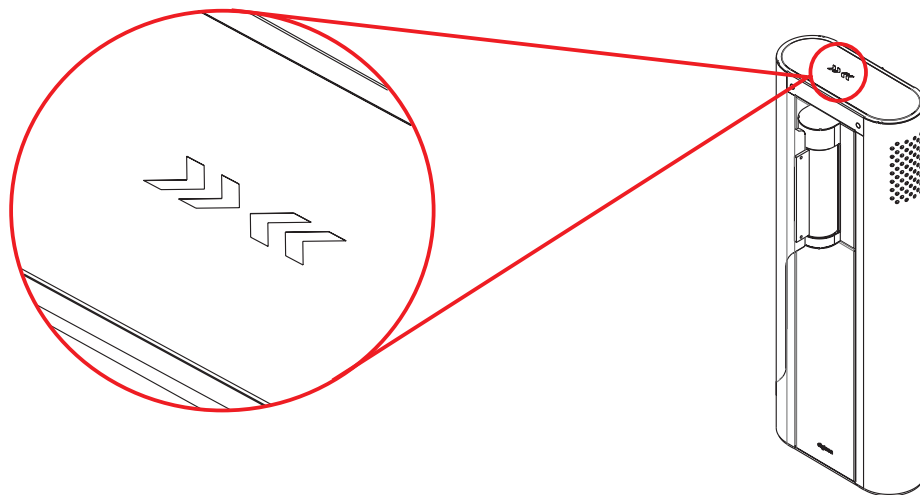

**b) Directional Pictogram (Front):**

The directional pictogram is installed at the ends of the equipment and is represented by a green arrow (<) or a red "X".

The red pictogram indicates to the user that the dTower is not operating in that direction, or that passage is currently not allowed, or the system is occupied.

The green pictogram informs the user that the dTower is free or controlled for passage in that direction.

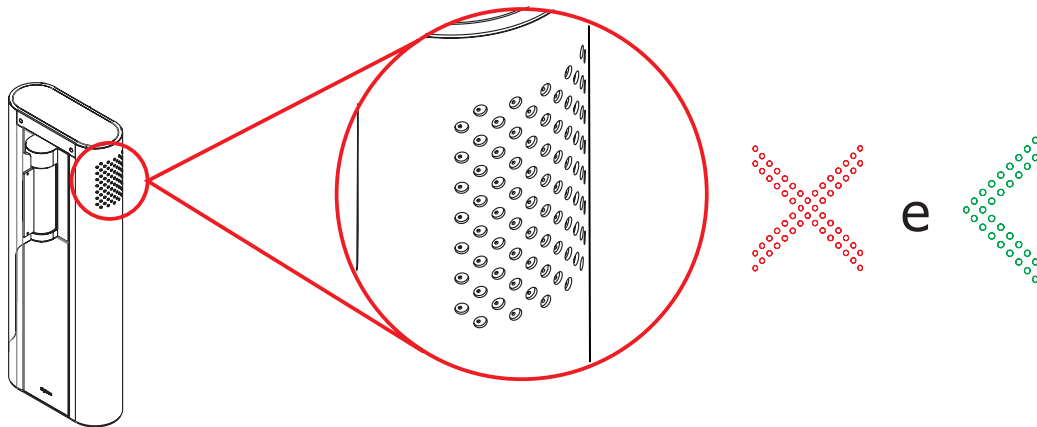

### 3.1 Functional Description

The dTower features a motorized system for opening and closing the access doors, which is triggered after the user's identification and access authorization. A sensor system is used to monitor the passage of individuals during access, controlling the direction of movement. These sensors also provide user protection.

The equipment operates with a brushless permanent magnet motor. Since the motor does not use a set of brushes for electrical activation, there is no mechanical wear of electrical contacts, extending the motor's lifespan.

To form a passage, two modules are always required. On the right side, observing the passage from the free area to the controlled area, there will be a Receiver module. On the opposite side, to the left, there will necessarily be a Transmitter module or a Receiver/Transmitter module, in the case of more than one passage. See the example below:

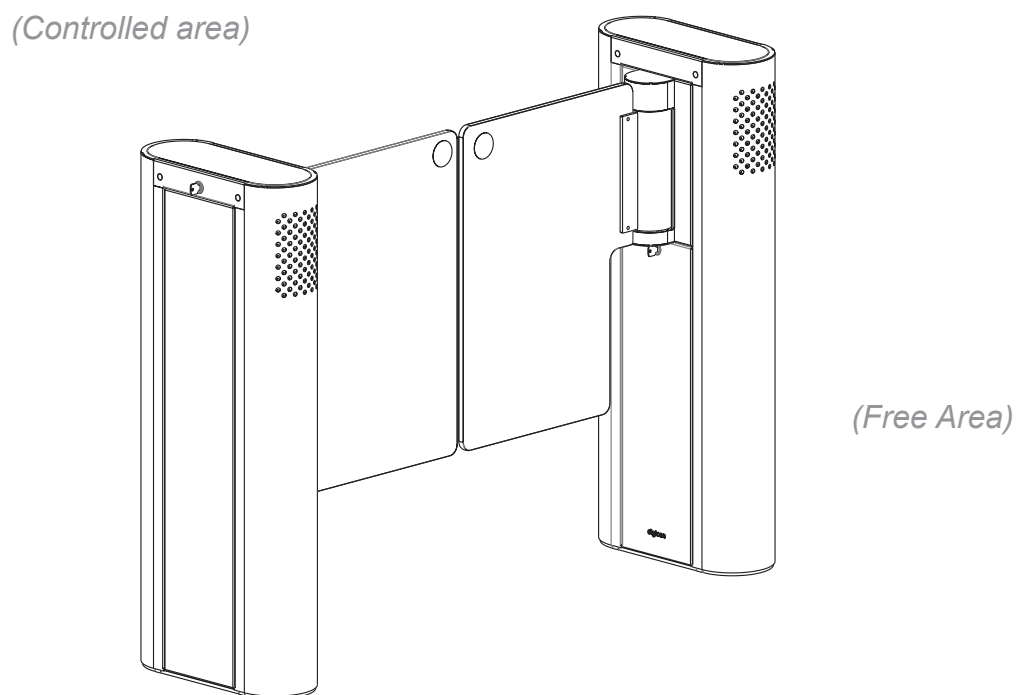

The dTower features a motorized system for opening and closing the access doors, which is activated after user identification and access authorization. A sensor system is used to monitor the passage of individuals during access, controlling the direction of movement. These sensors also provide protection for the user.

The equipment operates with a brushless permanent magnet motor. Since the motor does not use a set of brushes for electrical activation, there is no mechanical wear of electrical contacts, extending the motor's lifespan.

To form a passage, two modules are always required. On the right side, observing the passage from the free area to the controlled area, there will be a Receiver module. On the other side, to the left, there will necessarily be a Transmitter module or a Receiver/Transmitter module, in the case of more than one passage. See the example below:

**Receiver (R):** This is the side that houses the receiver sensors and the electrical panel, where the following components are installed: interconnection board, control board, power terminal block (BN1), and the power module. The interconnection cables are factory-installed on the receiver side.

**Transmitter (T):** This is the side that houses the transmitter sensors and the interconnection board (BN2).

 **ATTENTION!** - To form a complete layout with more than one passage, there are hybrid blocking modules called RT (Receiver + Transmitter).

**Receiver and Transmitter (RT):** This is a module that contains both a Receiver side and a Transmitter side. This module includes all the components listed above for R and T.



## 4. Unpacking, Mounting, and Electrical Connection

**⚠ ATTENTION!** - Only qualified technical professionals should install this equipment. The installation must comply with all local regulations and standards.

### 4.1 Unpacking the Package

As the items in the package may vary (depending on the customer's request), it is extremely important to perform a careful visual inspection before starting the installation and assembly process. All Digicon packages include a checklist, which serves as a guide for this inspection.

**⚠ ATTENTION!** - Upon receiving the equipment, check for any damage to the packaging. If there is any damage, take photos and send them to the responsible shipping company.

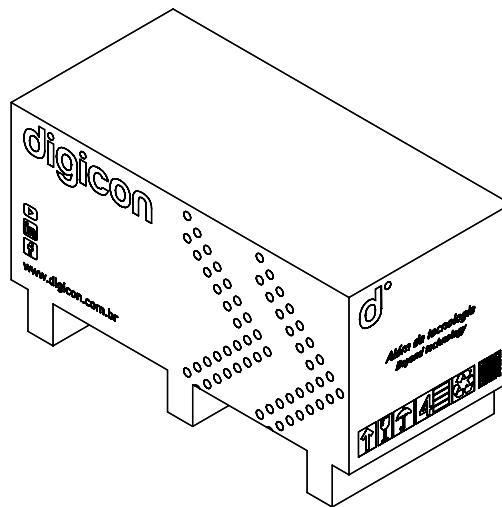

**⚠ CAUTION - RISK OF INJURY!** The packaging is heavy; it is necessary to use proper transport equipment, such as a pallet jack, to move it..

**⚠ CAUTION - RISK OF INJURY!** Always use the necessary PPE (gloves, safety shoes, and protective glasses).

#### 4.1.1 Packaging Dimensions:

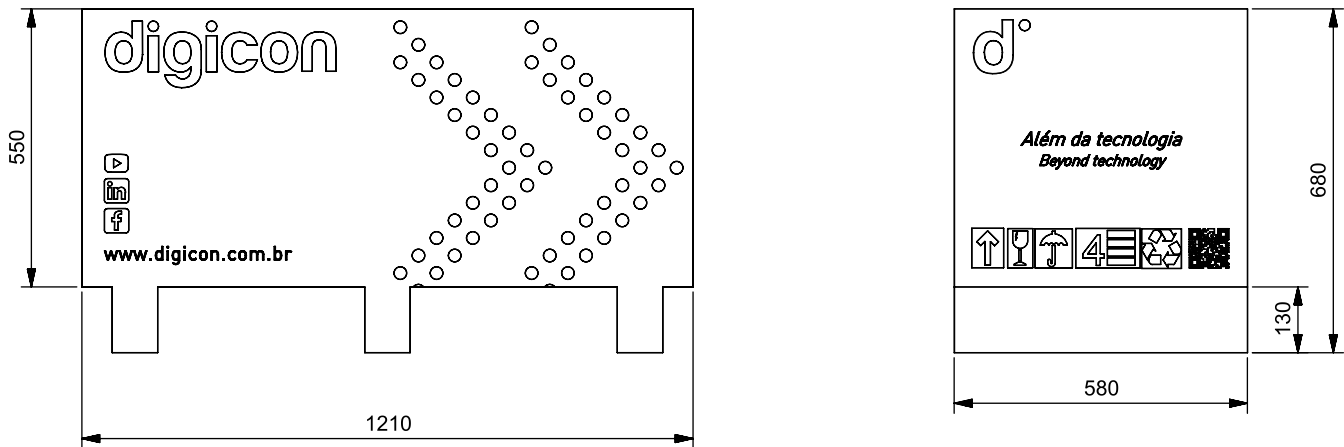

 **ATTENTION!** - The dimensions of the dTower are illustrated in millimeters.

#### 4.1.2 Necessary Tools:

- Protective gloves (PPE);
- Scissors or utility knife.

 **CAUTION - RISK OF INJURY!** When handling the cutting tools required to open the packaging, they may puncture or cut the person unpacking the equipment.

1. To open the cardboard box, use scissors or a utility knife to cut the straps securing the box to the pallet.

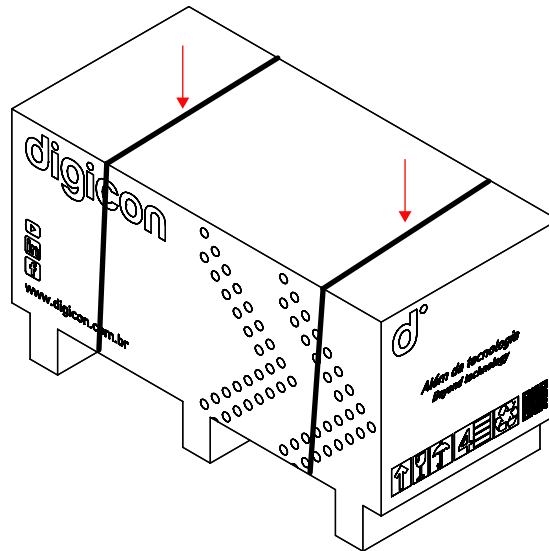

2. Remove the staples on the top of the box, and then open the four flaps of the packaging lid.

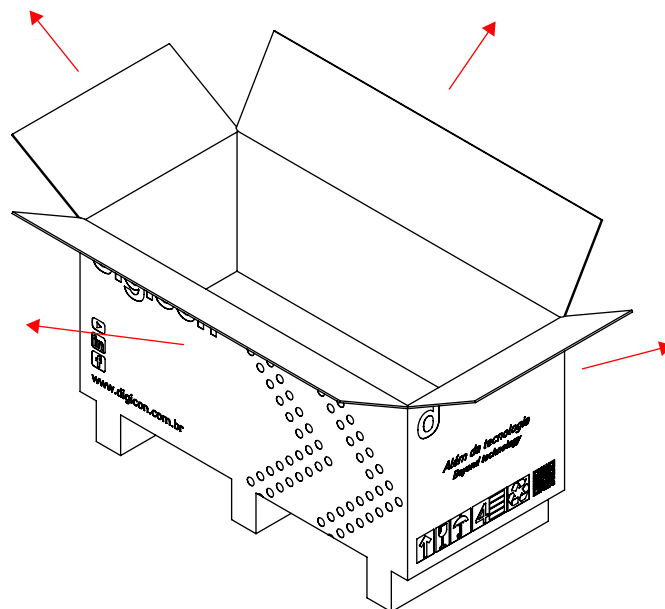

3. After opening, the parts of the dTower can be removed.

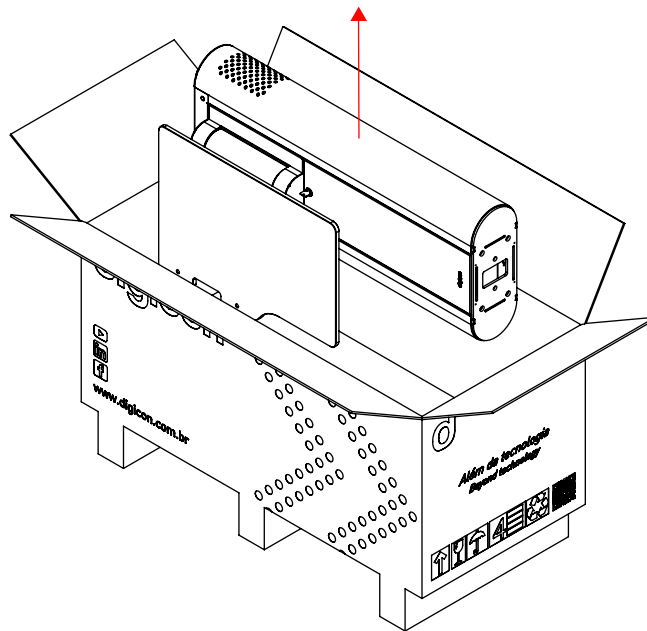

**⚠ CAUTION!** - Wear appropriate protective shoes, as heavy parts may fall onto the feet of the qualified technical professional.

**⚠ CAUTION - RISK OF INJURY!**: A minimum of two people are required to move the module.

### 4.1.3 Key Parts of the Product

The external parts of the equipment are listed below and identified by numbers in the figure below.

1. Operation pictogram;
2. Orientation pictogram;
3. dTower R module
4. Internal access door.
5. Identification label (by color);
6. dTower T module;
7. Top cover lock;
8. Top cover;
9. Swing Gate door.

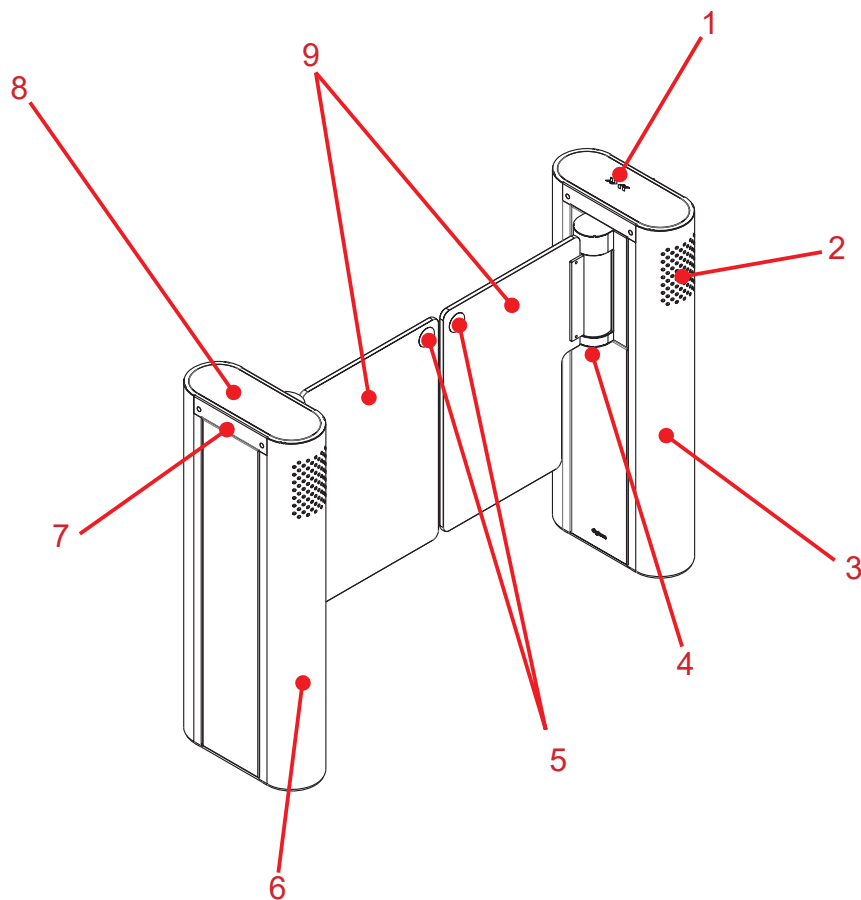

## 4.2 Fixation

### 4.2.1 Before installing the dTower, check:

- If the chosen location for the equipment installation is firm and level. It must meet the following requirements for flatness and leveling, respectively:  
(Standards: ASTM E 1155-96 and ACI 117-90)
- **PP ≥ 25 (Floor Flatness)**
- **NP ≥ 20 (Floor Levelness)**
- If there is a power source near the location, compatible with the equipment's power consumption;
- If the chosen location is suitable for the installation of the access controller (indoor environments);
- If the floor is in condition to receive anchor bolts (minimum 4 cm of concrete FCK15 M.P.A. or equivalent). Digicon recommends anchor bolts from the HILT brand;
- If the junction boxes and conduit pipes for electrical and data cables are properly installed;
- If all the necessary tools are available;
- If all the necessary PPE for installation is available.

 **ATTENTION!** - Since the installation of the dTower requires drilling the floor, it is extremely important that the installation location is carefully chosen.

**Positioning Template:** The template must be requested, as it is an item sold separately from the product.

## 5. Installation and Assembly

### 5.1 Unpacking

Since the dTower is a configurable equipment, it is extremely important to perform a careful visual inspection before starting the installation and assembly process. If any part is missing, contact the Digicon representative responsible for the sale immediately.

Two people are required to remove the equipment from the box;

The top flaps of the box can be folded in half, making it easier to access the equipment;

Be careful when removing the equipment from the box to avoid damaging it.

### 5.2 Pre-Installation

Before starting the installation of the dTower, the floor where the equipment will be fixed must be prepared. The embedded boxes must be installed before fixing the dTower. There is an opening at the bottom of the equipment, and the embedded boxes must be placed directly in the center of it.

The floor must be firm and level to ensure the proper functioning of the equipment.

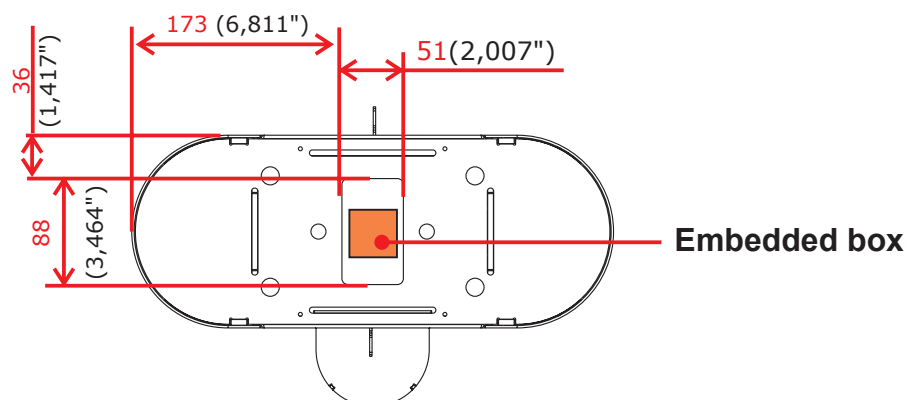

**⚠ ATTENTION!** - The measurements are illustrated in millimeters and (inches).

The distance between the boxes depends on the size of the doors. The doors should be adjusted to have a small gap of approximately 30mm between them. This gap is important to ensure that even when the door is closed, it will not harm the user.

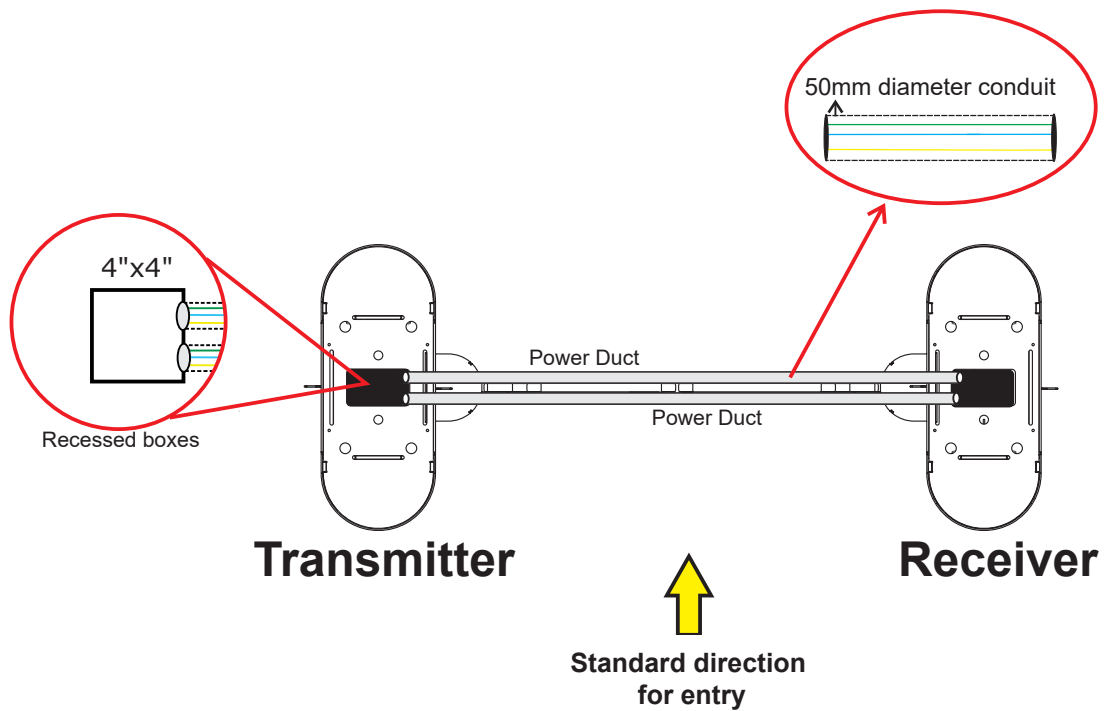



### 5.3 Floor fixation

The image below indicates the product's floor fixation points.

The surface must be firm and leveled to ensure proper functioning of the access control system and to maintain the alignment of the doors.

The fixation should be done using mechanical anchors, also known as parabolts, or through chemical fixation.

For mechanical anchors, the minimum floor thickness must be 100mm.

For cases where the floor thickness is less than 100mm or for special floors, chemical fixation must be used.

**⚠ ATTENTION!** - To facilitate tightening the screws, a long extension must be used.

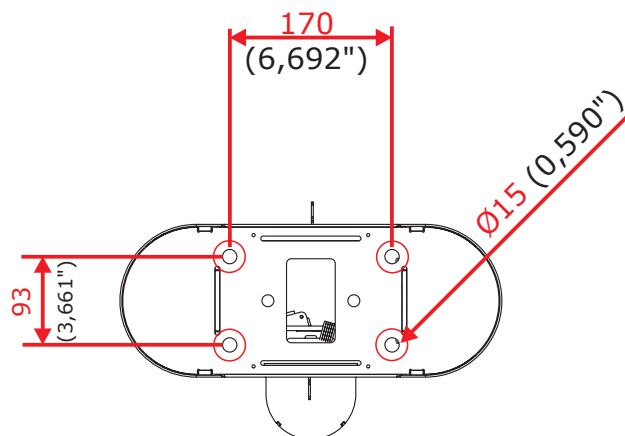

**⚠ ATTENTION!** - The measurements are illustrated in millimeters and (inches).

It is very important to check the alignment of the doors in the closed position during installation. The distance between the doors must be the same from the top to the bottom.

**Free passage gap:**

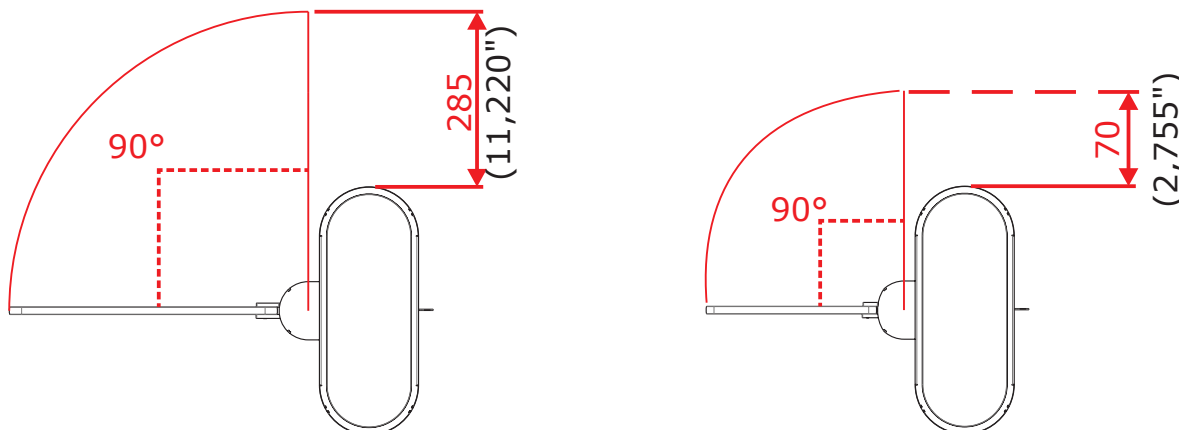

**⚠ ATTENTION!** - Digicon complies with the ABNT NBR 9050 standard for Accessibility to buildings, furniture, spaces, and urban equipment.

**Step by step:**

1. Using a 12mm (0.47") drill bit, make a hole with a depth of 90mm. (M10 threaded rod);
2. Clean the hole with a blower or vacuum to remove the dust residue;
3. Place the threaded rod inside the hole to measure the depth. The rod has a mark that should be flush with the ground;
4. Insert the HVU capsule into the hole;
5. Secure the threaded rod in the drill and screw it in until it reaches the bottom of the hole or until the mark on the threaded rod is flush with the ground;
6. Use the drill until the chemical material rises to the surface;
7. Do not touch the threaded rod to allow the chemical reaction time (10 minutes);
8. Curing time according to the table:

Data according to ETA 05/0255/0256/0257, edition 2010-03-01 / 2006-01-20	
Base material temperature	Curing time required for fixation Can withstand the full load
20°C to 40°C	20min
10°C to 19°C	30min
0°C to 9°C	1 hour
-5°C to -1°C	5 hours

## 5.4 Fixing the doors

The dTower is packaged with the doors uninstalled, meaning they are included with the equipment but separately (apart). This is done to prevent damage to the equipment and the door(s).

**To install/fix the doors, simply follow the steps below:**

1. Place the screw (1) only in the upper part, into the hole of the fastener (2).
2. With the screw inside the fastener (2) hole, insert it into the door hole (4).
3. With all three parts aligned, fix them to the motor (5) of the equipment.
4. Once the upper part is fixed, place screw (3) in the lower part, passing through the fastener (2), the door (6), and the motor (7).
5. With the door suspended, align it before tightening the screws completely.
6. Using a torque wrench, it is recommended to apply a force of 20Nm for the final tightening of the screws.

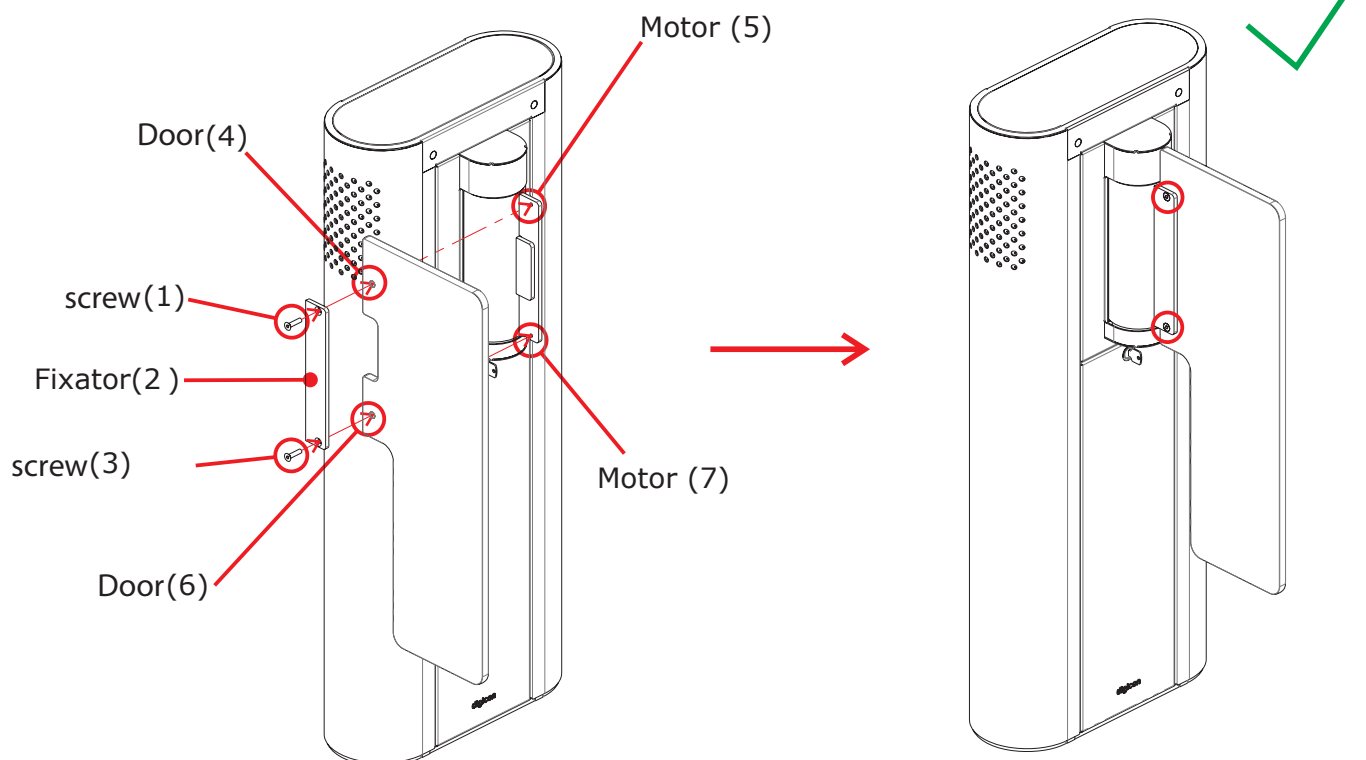

### 5.4.1 Labels

Along with the equipment, passage identification labels are provided. These are circles in blue or yellow:

**Blue:** they identify passage for people with special needs (PNE), with a passage width of 920mm.

**Yellow:** they identify passage for people without special needs, with a passage width of 520mm.

#### Passage identification label

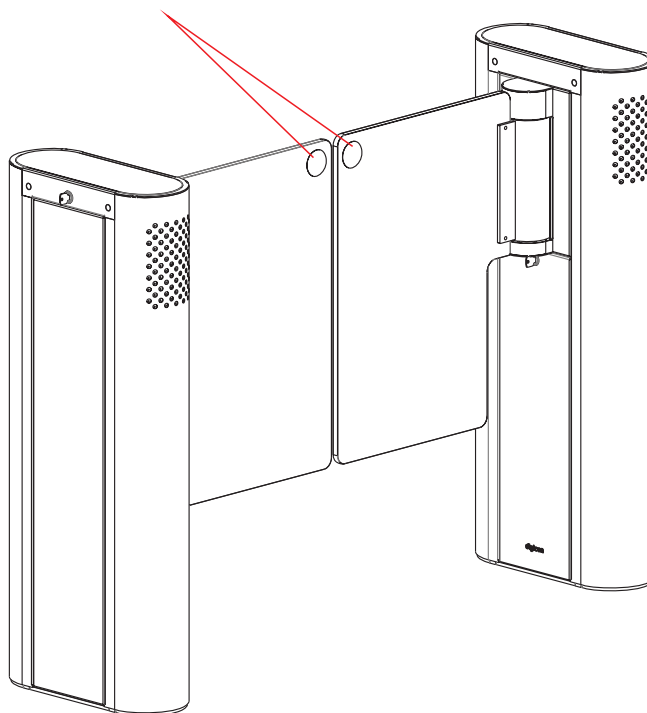

 **ATTENTION!** - The use of passage identification labels is optional.

## 5.5 Access to the dTower after assembly

**⚠ WARNING - RISK OF DEATH!** To reduce the risk of electric shock, before performing maintenance, turn off the power to the equipment by switching the circuit breaker to the OFF position. Reserve all maintenance services for qualified technical professionals only.

After the dTower is installed and assembled, access to the internal part of the equipment can be made using the key that comes with the equipment, through 2 methods:

**1° Through the top cover:** provides access to the readers, pictograms, and motor plate;

**2° Through the access door:** provides access to the controller board, interconnection board, AC terminals, circuit breaker, and power supply.

Lock for opening upper cover

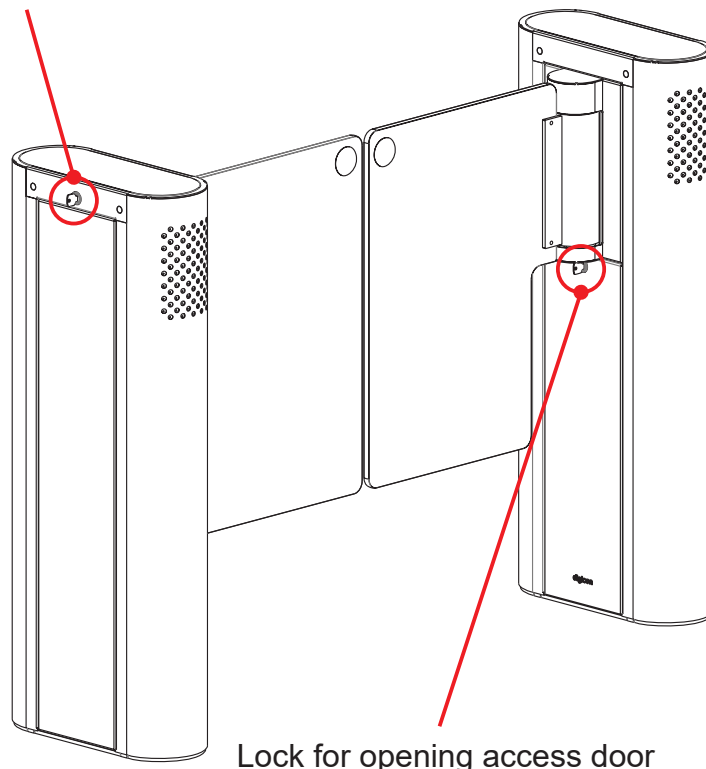

## 6. Electrical connection

### 6.1 Interconnection of equipment

**⚠ WARNING - RISK OF DEATH!** To reduce the risk of electric shock, before maintenance, turn off the equipment's power by switching the circuit breaker to the OFF position. Reserve all maintenance services for qualified technical professionals only.

The interconnection cables are located in the dTower R and must pass through the ducts as shown below.

Duct for interconnection of signal and DC power cables:

- 037.12.909 - Signal and DC Power Interconnection Cable dTower.

Insert connectors CN4, CN5, and CN6 into their respective locations as indicated on the silkscreen of the dTower T interconnection board.

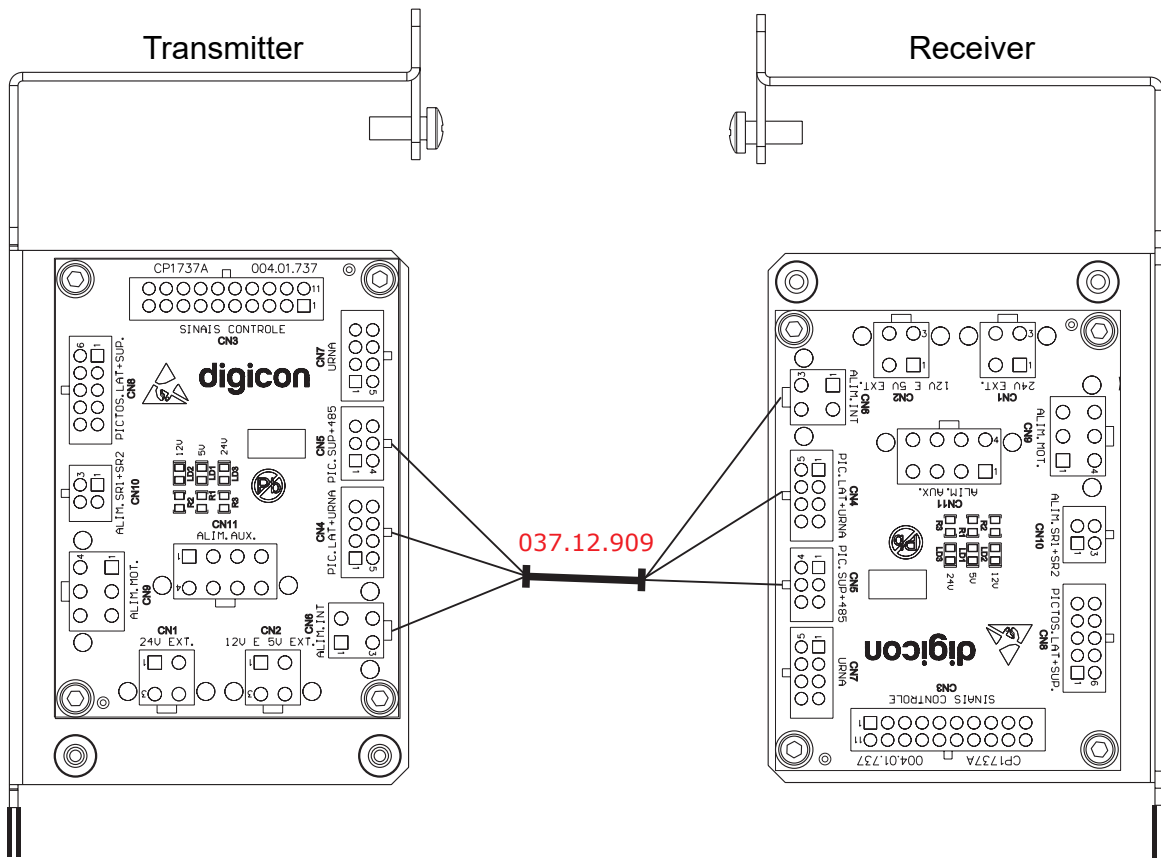

Interconnection conduit for the AC cable:

- 037.12.253 - dTower AC power cable.

Layout 1:

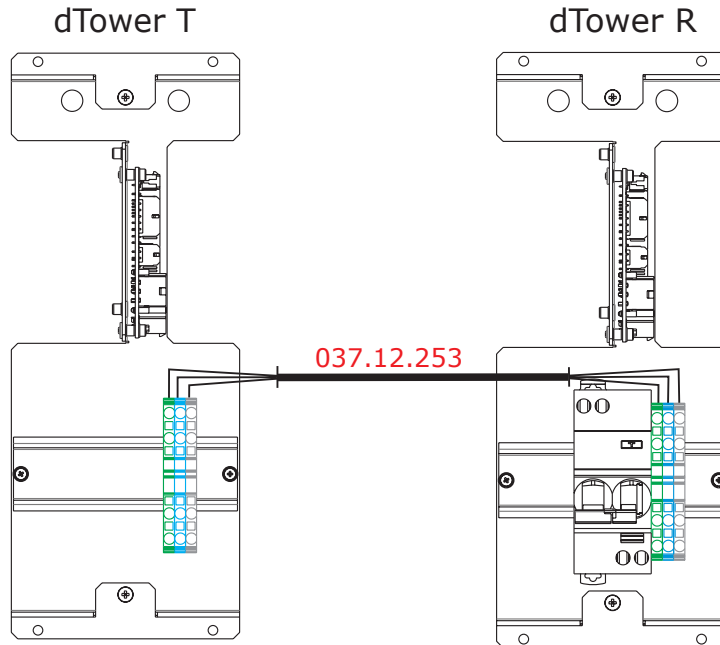

Layout 2:

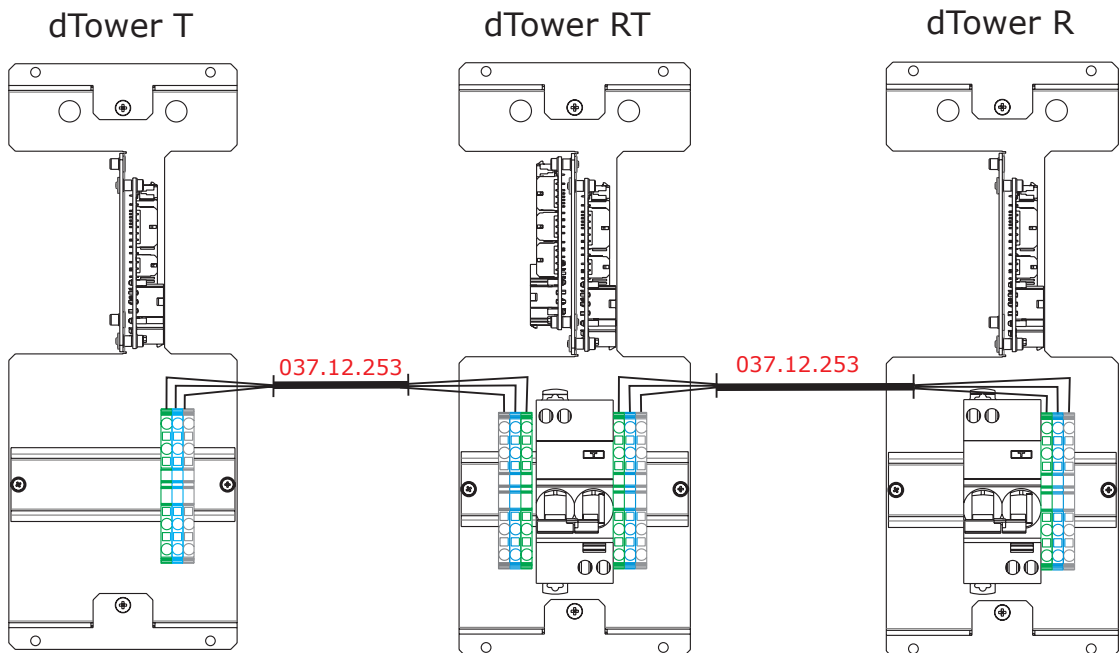

**⚠ ATTENTION!** - The cable itself has rings indicating where each cable should be connected.

**⚠ ATTENTION!** - Separate the electrical network from the logical network.

**⚠ ATTENTION!** - Digicon provides interconnection cables with a length of 3 meters.

**⚠ ATTENTION!** - The depth of the ducts must be sized to ensure that the cables are sufficient.

## 6.2 Connection to the power grid:

**⚠ WARNING - RISK OF DEATH!** To reduce the risk of electric shock, before performing maintenance, turn off the power to the equipment by switching the circuit breaker to the OFF position. Reserve all maintenance services for qualified technical professionals only.

The connection must be made as shown in the figure below:

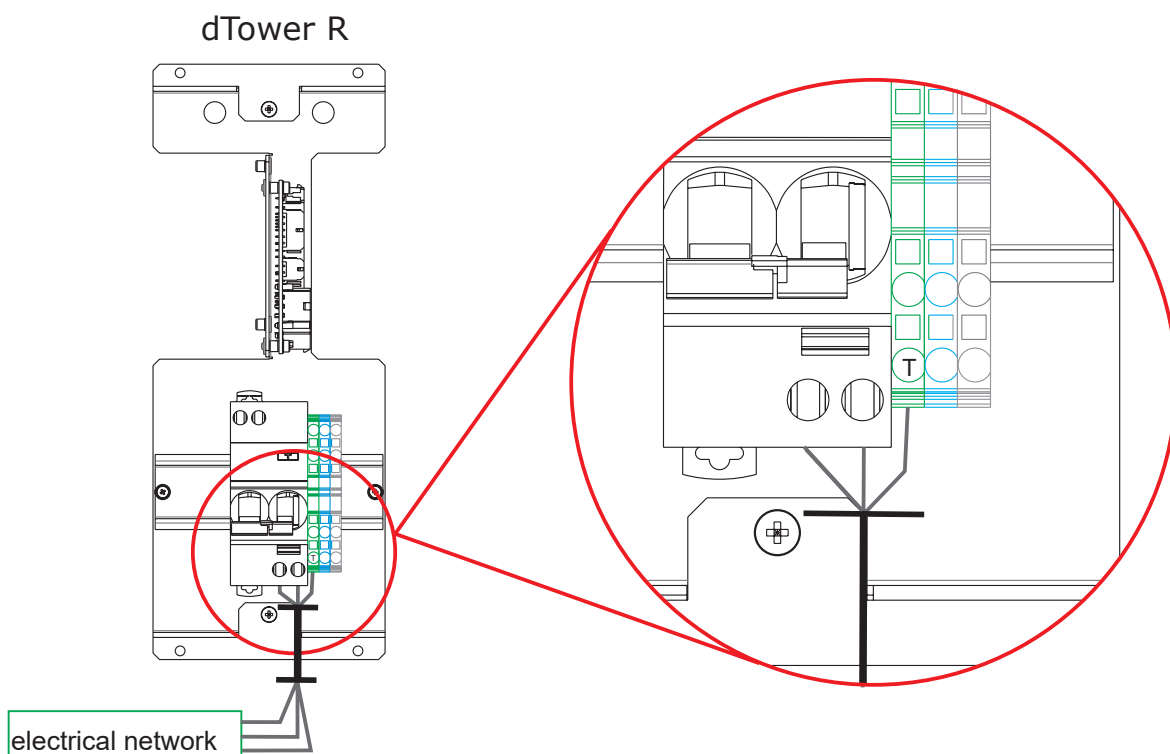

Digicon recommends using the NBR 5410 standard as a reference for the electrical installations of the equipment.



The power supply cables should be connected to the circuit breaker, and the grounding cable should be connected to the green/yellow terminal.

**⚠ ATTENTION!** - We recommend that the AC power cable and grounding cable be of good quality and with dimensions compatible with the distance to the distribution panel. The data cable should be of the CAT5E type.

## 6.3 Connection of control signals

### Activation by dry contact 2 relays

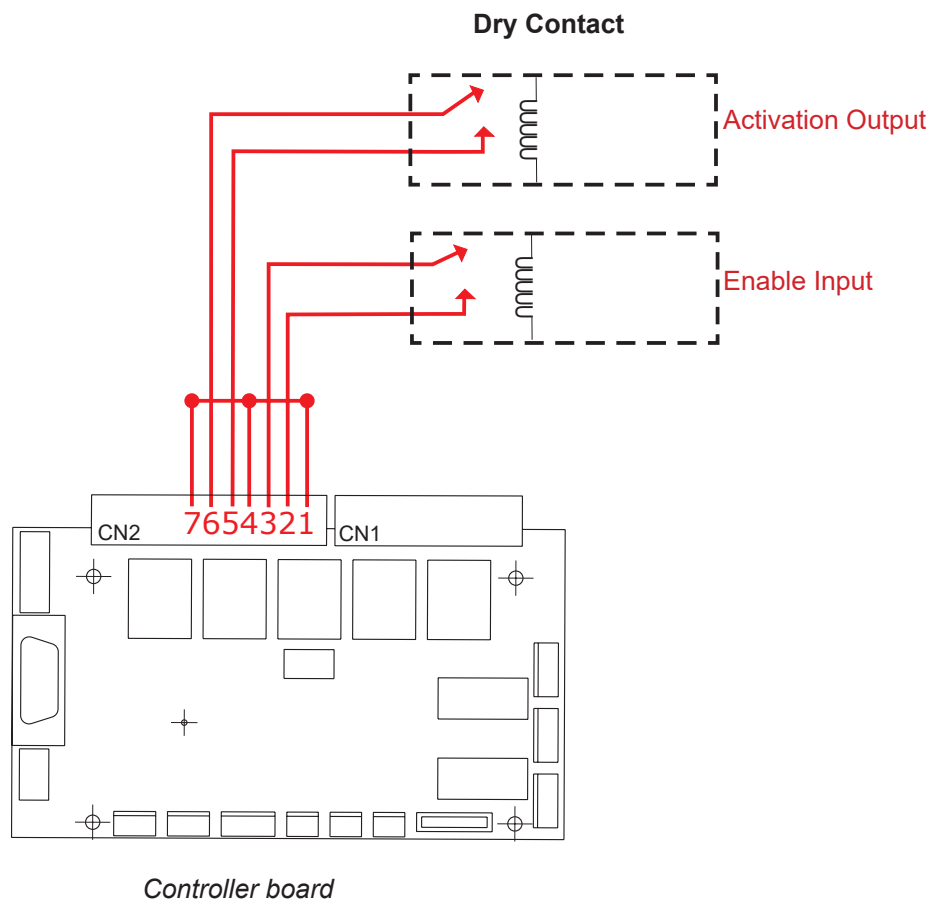

**Solid-state activation (positive, positive voltage):**

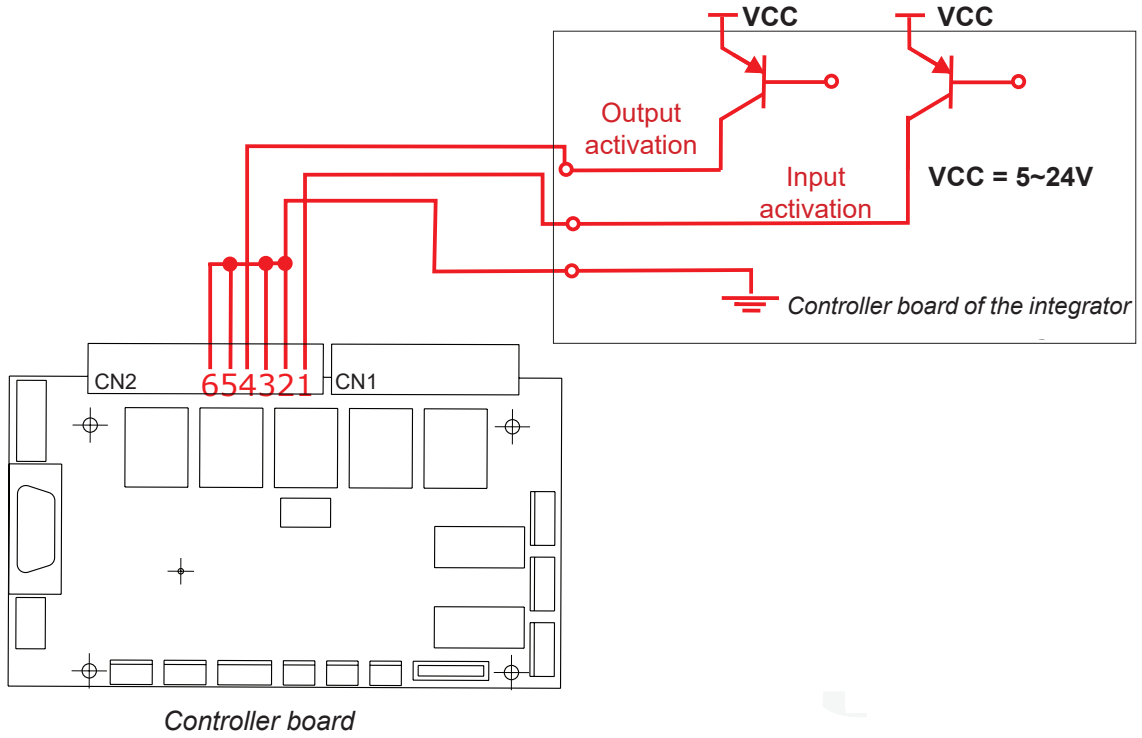

**Solid-state activation (negative):**

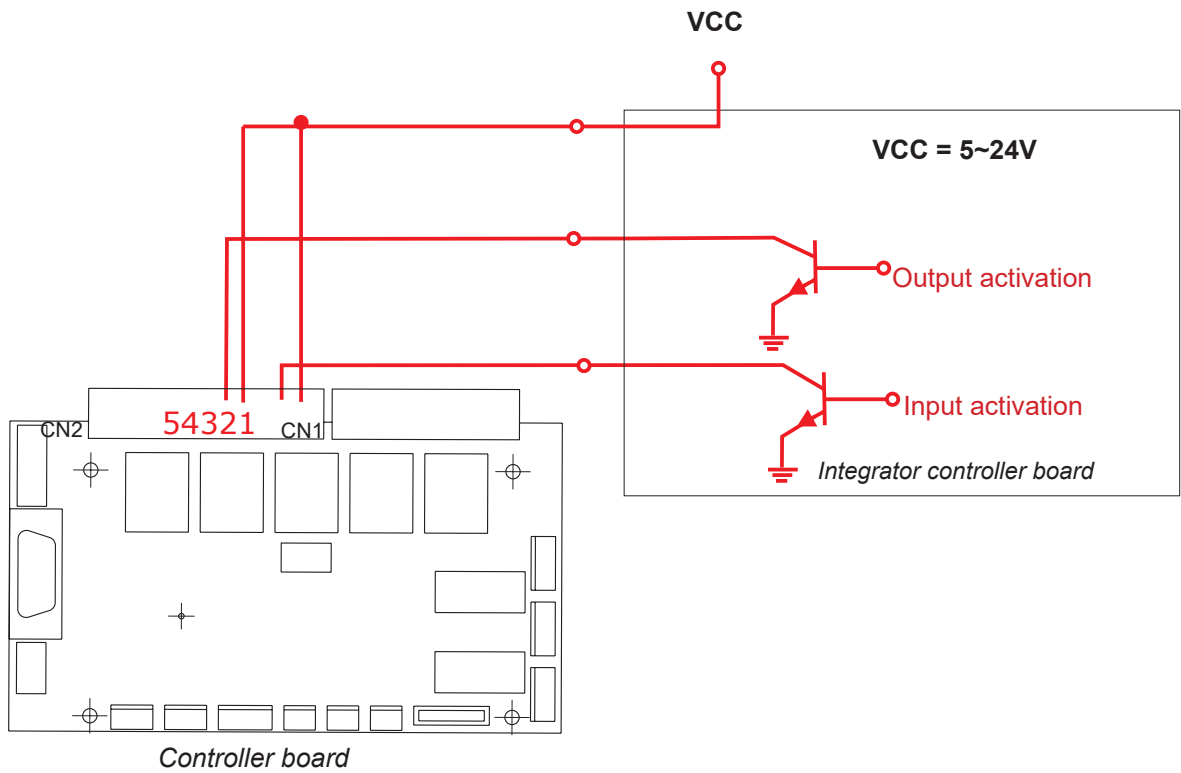

**Passage confirmation**

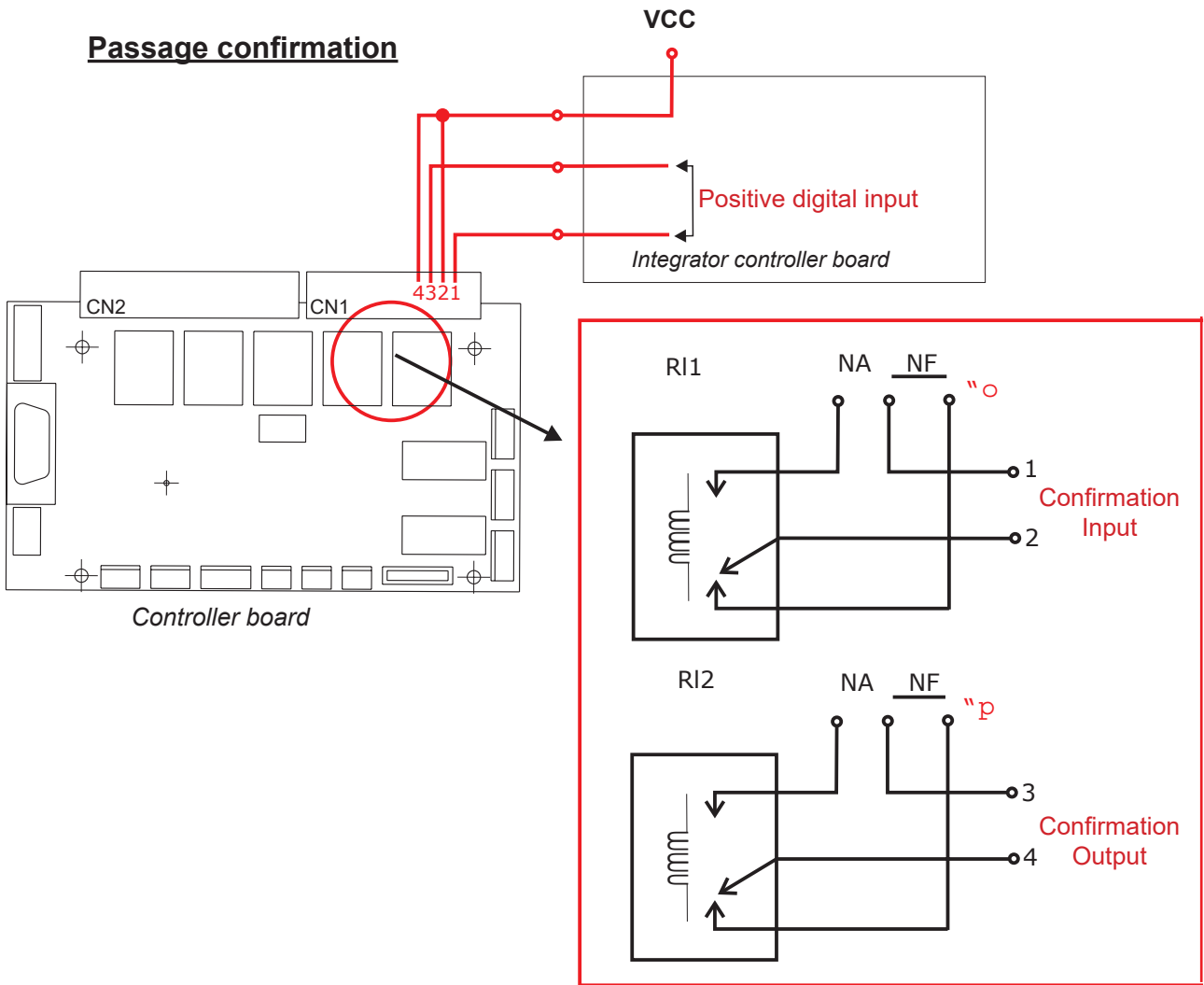

Vcc - true logic level, configured in "disk emulation" DIP switch DS2 number 7 in ON.

**Passage confirmation - Negative:**

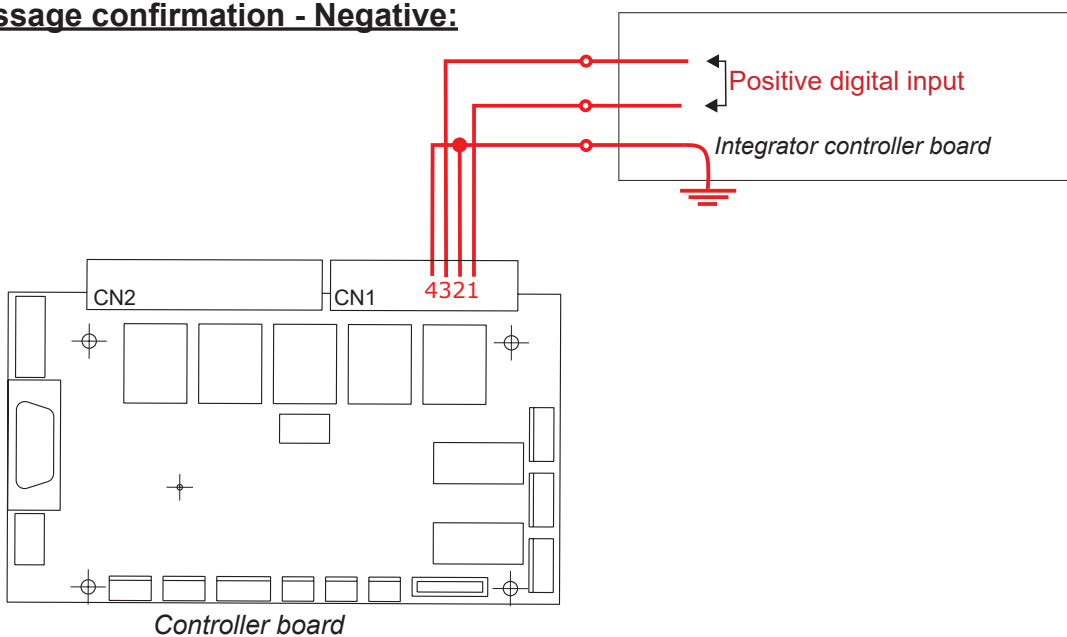

**Confirmation of passage by disk emulation**

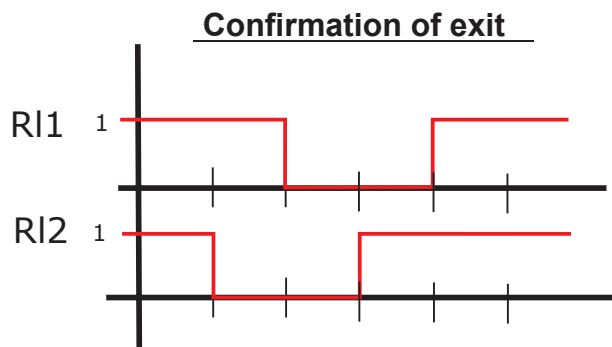
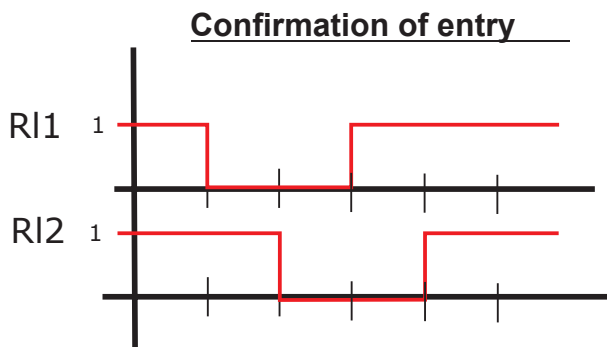

In this operating mode, any of the passage confirmation outputs - output RI1 or RI2 - can be used to activate an electromechanical counter to record the passage flow in both directions of the equipment.

**Passage confirmation by pulses:**

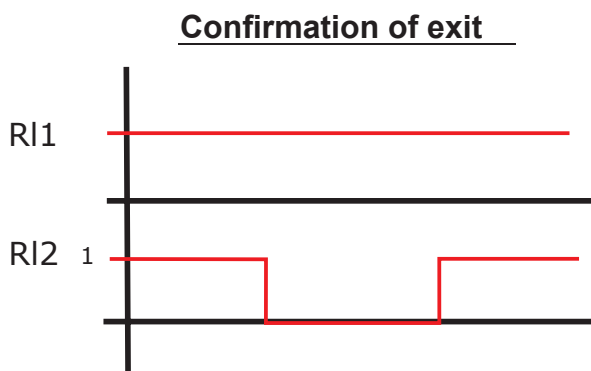
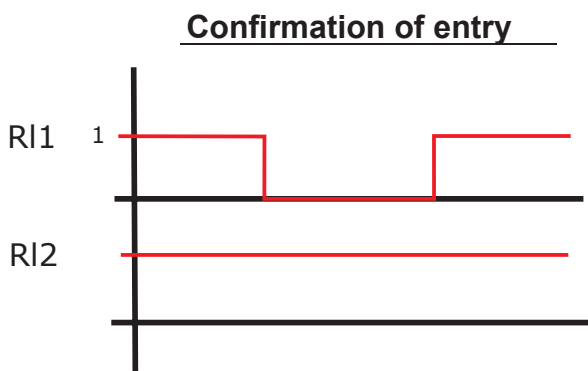

In this operating mode, the RI1 output can be used to activate an electromechanical counter to record the passage flow in the entry direction of the equipment. Similarly, the RI2 output can be used to record the passage flow in the exit direction.

Passage confirmation by pulse or “disk emulation” can be configured using dip switch DS2, no. 7. If the switch is in the ON position, disk emulation will be enabled. Otherwise (OFF), a passage confirmation pulse will be generated.

## 6.4 dTower Operation

 **WARNING - RISK OF DEATH!** To reduce the risk of electric shock, before maintenance, turn off the equipment's power by switching the circuit breaker to the OFF position. Reserve all maintenance services for qualified technical professionals only.

The dTower R will always be the master module of the barrier. In this module, the control board responsible for the barrier's operation is installed.

### 6.4.1 Control board

The control board has the functionality to manage user passage, pictograms, sensors, and the entire system logic, receiving signals from the access control board.

### 6.4.2 Functionalities

The dTower offers various functionalities, some of which can be configured using the DS1 and DS2 selection switches located on the controller board.

To program DS1, set each switch to the desired position according to the table below.

 **ATTENTION!** - The gray squares (in bold) in the tables below indicate the default configuration, i.e., the factory setting.

DIP SWITCH DS1								
Key	1	2	3	4	5	6	7	8
Activates the intrusion sound alert	ON							
Deactivates the intrusion sound alert	<b>OFF</b>							
Entry signal for activation: NO contacts		<b>ON</b>						
Entry signal for activation: NO contacts		OFF						
Allows invasion			ON					
Does not allow invasion			<b>OFF</b>					
Activates entry access released (keep in off)				ON				
Deactivates entry access released (keep in OFF)				<b>OFF</b>				
Activates exit access released (keep in OFF)					ON			
Deactivates exit access released (keep in OFF)					<b>OFF</b>			
Activates sound alert 2 seconds before closing						<b>ON</b>		
Deactivates sound alert 2 seconds before closing						OFF		
No maximum time - waits for valid passage							ON	ON
Maximum time of 5 seconds							<b>OFF</b>	<b>ON</b>
Maximum time of 10 seconds							ON	OFF
Maximum time of 15 seconds							OFF	OFF

To program DS2, place each switch in the desired position according to the following table.

 **ATTENTION!** - The gray squares (in bold) in the tables below indicate the default configuration, i.e., the factory setting.

DIP SWITCH DS2								
Key	1	2	3	4	5	6	7	8
End time to close door: 0.50s	<b>ON</b>	<b>ON</b>						
End time to close door: 1.25s	OFF	ON						
End time to close door: 2.00s	ON	OFF						
End time to close door: 5.00s/SMART SPEED	OFF	OFF						
Activates credit accumulation			ON					
Deactivates credit accumulation			<b>OFF</b>					
Door movement speed: LOW				<b>ON</b>				
Door movement speed: HIGH				OFF				
Activates Safe Mode (does not close the doors even with obstructed sensors)					<b>ON</b>			
Disables Safe Mode (closes the doors even with sensors obstructed)					OFF			
Card retention time in the reader for reading: 1s						<b>ON</b>		
Card retention time in the reader for reading: 2s						OFF		
Confirmation of passage by disk emulation							<b>ON</b>	
Confirmation of passage by pulse							OFF	
Operating mode with sensors								<b>ON</b>
Operating mode without sensors								OFF

The detection of user passage is quite strict, requiring the following events to occur, in this order:

- 1- Block the first sensor;
- 2- Block the second sensor (without releasing the first). At this point, both sensors must be blocked;
- 3- Release the first sensor;
- 4- Release the second sensor.

If the events above do not occur in the indicated order, the system may interpret this change as an invasion, piggybacking, or abandonment, and will signal accordingly based on its interpretation.

For the proper functioning of this function, it is essential that the sensors on the receiver side are properly configured with the keys as shown in the image below.

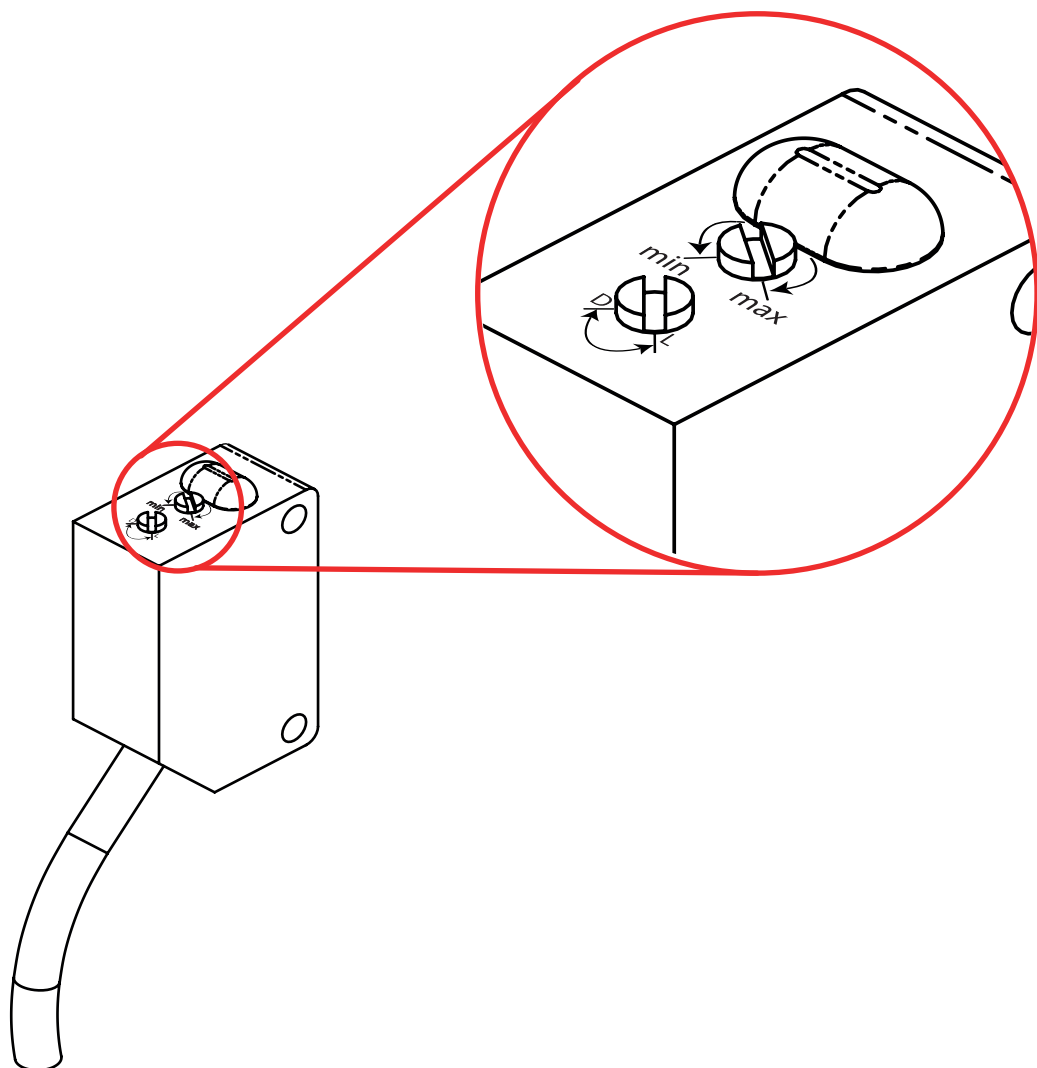



**⚠ ATTENTION:** the upper sensitivity switch must be in the “Max” position and the lower switch in the “L” position, as specified.

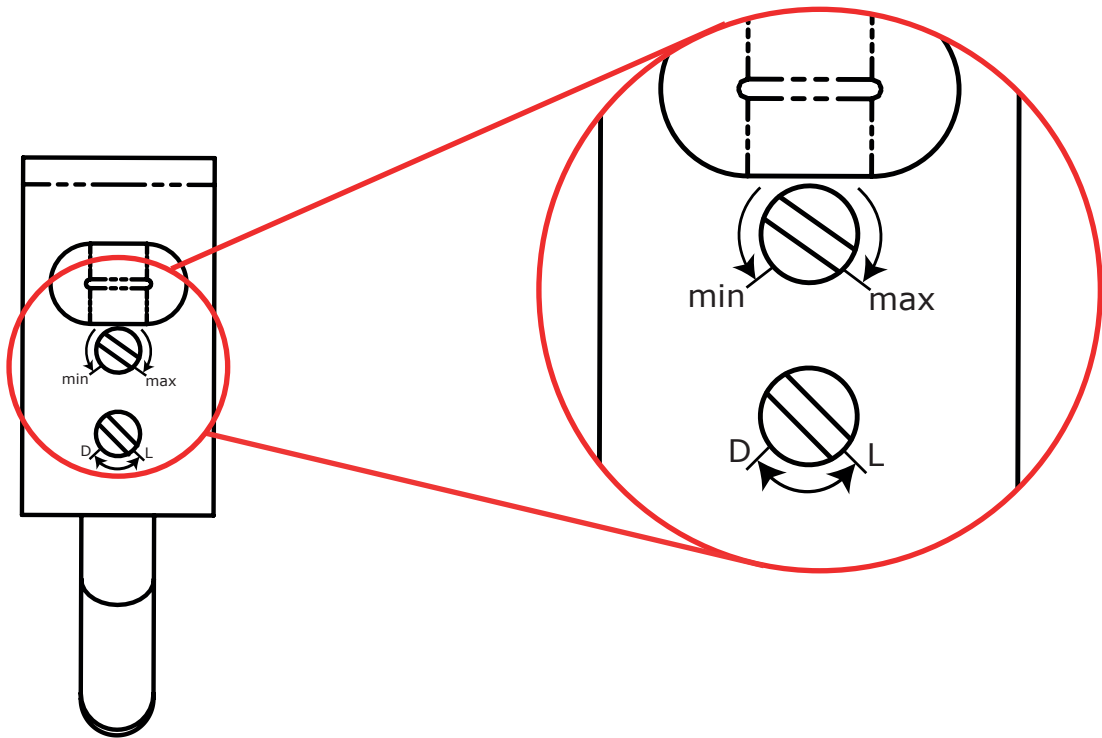

#### a) Enabling pulse:

The enabling pulse is a signal (dry contact relay) sent by the access control system, indicating that the user has been identified and granted permission to pass. Passage is enabled by the voltage level of the enabling pulse, which must last at least 20ms and respect a minimum interval of 20ms between pulses. If the pulse does not comply with these intervals, the enabling will be ignored. If the pulse duration exceeds the passage cycle, no new passage will be granted, meaning the signal must be turned off for 20ms.

**⚠ ATTENTION!** - This function also depends on the access management system supporting the queue for consecutive accesses.

In the images below, NC and NO contacts respectively, each image illustrates two examples of valid pulses, one of 20ms and another of 150ms with an interval of 200ms between them. In this situation, if the credit accumulation function is enabled, the dTower would count two accesses, allowing two people to pass consecutively without the door closing.

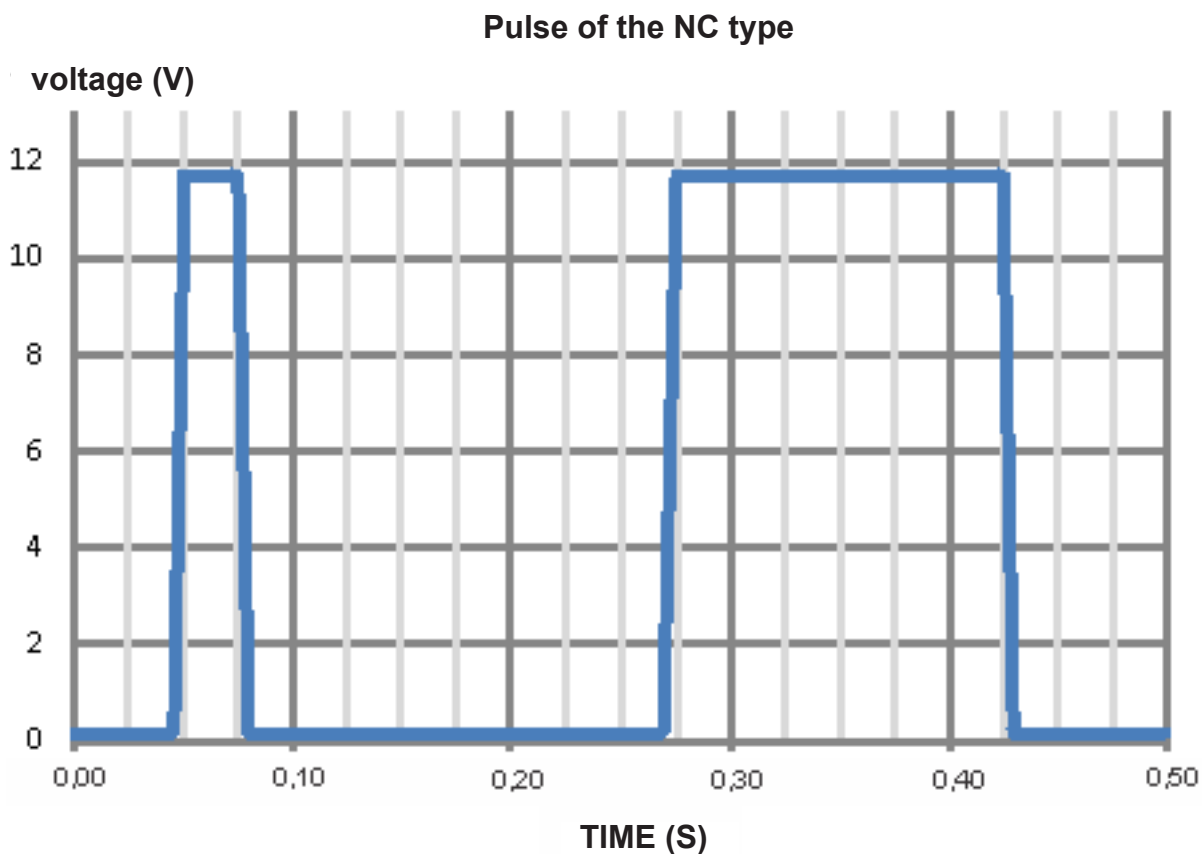

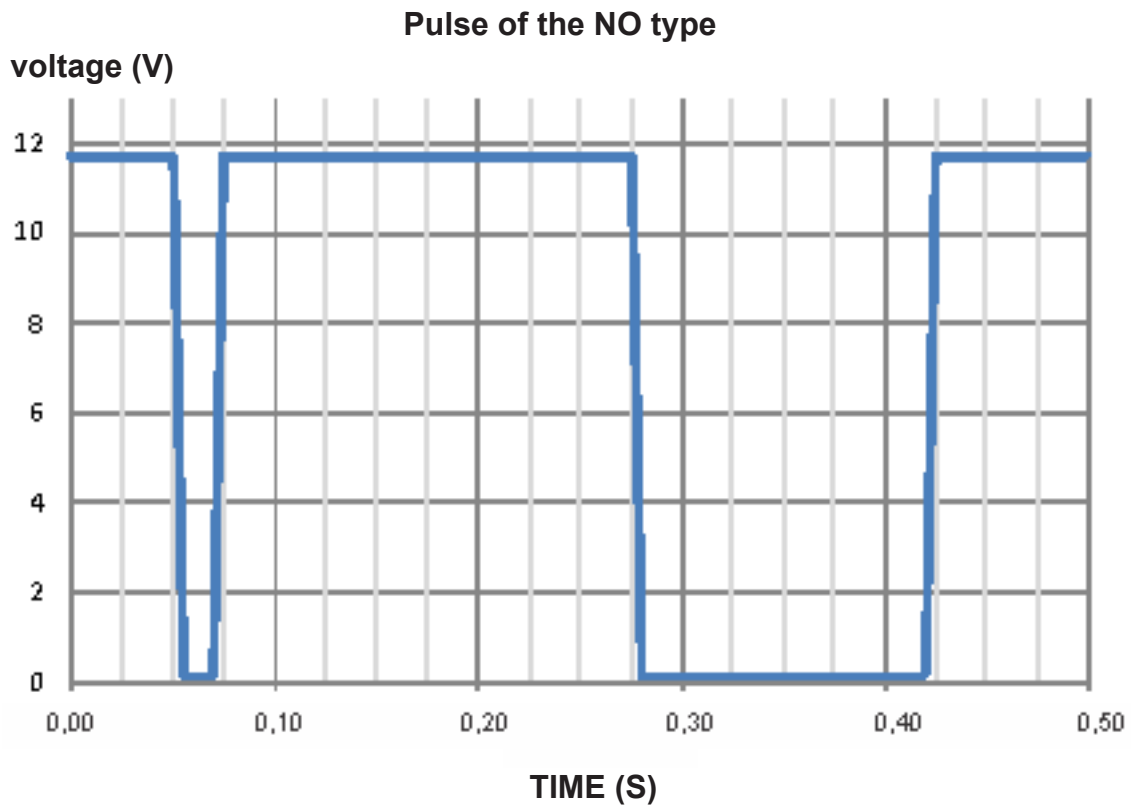

#### 6.4.2.1 Configurable Functions (via inputs)

##### a) Free pass:

**Activation: send the entry and exit commands simultaneously and keep them active.**

The free passage mode is suitable for situations that require the system to remain unlocked indefinitely and without passage control. It can be used as an emergency mode in locations where legislation allows simple control for unlocking. In areas with stricter legislation, a main switch should be used to cut power to the system, leaving the door free.

During free passage mode, the door remains open for exit, and the top pictograms flash indefinitely. This mode remains active as long as the entry and exit enable signals are present.

**b) Bidirectional release:**

In this mode, the equipment waits for the user's interaction to determine in which direction to release the passage and then opens the door correctly. This interaction occurs by gently pushing the door in the direction in which the user wishes to pass after the equipment indicates the release. This type of release is particularly useful in passages that share a single reader for both directions.

The activation of the bidirectional release occurs by sending both the entry and exit commands simultaneously for the minimum activation time of 20ms.

**⚠ ATTENTION!** - Switch or relay with two poles and single activation.

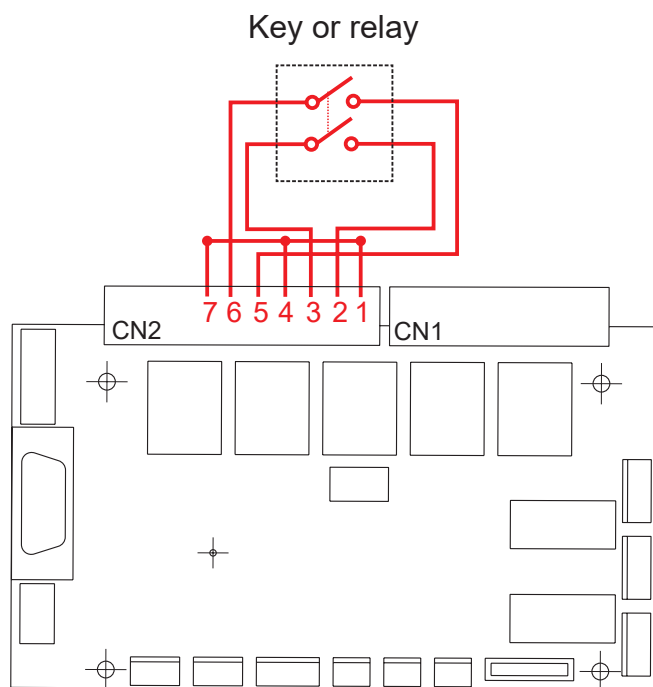

### 6.4.2.2 Configurable Functions (via DS1)

#### a) Intrusion Sound Alert:

Selection: DS1-P1 ON.

This function, when activated, emits sound signals when the following events occur:

- Invasion from either side of the blocking area with the door closed.
- Invasion against the direction allowed for passage with the door open.

User piggybacking;

#### b) NO or NC contact:

Selection: DS1-P2 ON for NO contacts, OFF for NC contacts. This allows the selection of the enabling pulse activation logic, which can be by relay with normally open or normally closed contacts.

#### c) Passage with or without invasion:

**Selection:** DS1-P3 in ON allows invasion, in OFF does not allow invasion. This function determines whether the system allows or disallows sensor obstruction while in standby mode. If the function is set to disallow invasion, whenever one of the sensors is obstructed, the upper pictograms will indicate an invasion, and the sound alert (if enabled) will beep. In this situation, passage will not be allowed, even if the user is authorized. On the other hand, if the function allows invasion, no alert will be issued, and the user's validation will proceed normally.

**d) Mode of Access Granted:**

Selection: DS1-P4 and DS1-P5.

The access granted mode can be used in special events where it is necessary to keep the equipment open in a specific direction, either entry or exit. It can also be used as a test to verify the door's functionality. When the DS1-P4 switch is activated, the door will open for entry and remain in this state until it is disabled. The same happens for DS1-P5, but the door opens for exit.

By keeping both switches activated, the equipment remains in demonstration mode, where it performs continuous opening and closing movements at intervals of approximately 4 seconds.

**e) Closing Sound Alert:**

Selection: DS1-P6 ON.

When activated, this function emits a continuous beep two seconds before the maximum passage time ends and the door closes. The selection of the maximum passage time is defined in DS1-P7 and P8.

**f) Maximum passage time:**

Selection: DS1-P7 and DS1-P8.

This function sets the maximum time allowed for the user to pass through. It is possible to define times of 5s, 10s, 15s, or an indefinite time (waits until a valid passage occurs).

### 6.4.2.3 Configurable Functions (via DS2)

#### a) Waiting time at the end of passage:

**Selection DS2-P1, DS2-P2:** This feature allows you to select the waiting time to close the door at the end of a valid passage or after the sensors are unlocked when the “Safe Mode” is enabled. When “Safe Mode” is enabled, the times can be 0.5 second, 1.25 seconds, 2.0 seconds, or 5.0 seconds. When “Safe Mode” is disabled, the times can be 0.5 second, 1.25 seconds, 2.0 seconds, or Smart Speed. In Smart Speed mode, the system measures the passage speed and calculates the time for the person to safely pass through the lock zone. The lock zone extends to the maximum distance the door can reach, plus 100mm, as indicated in the hatched region of the figure below. In Smart Speed mode, the minimum and maximum times are 0.5 and 10 seconds, respectively. The Smart Speed function works correctly as long as the passage speed is constant.

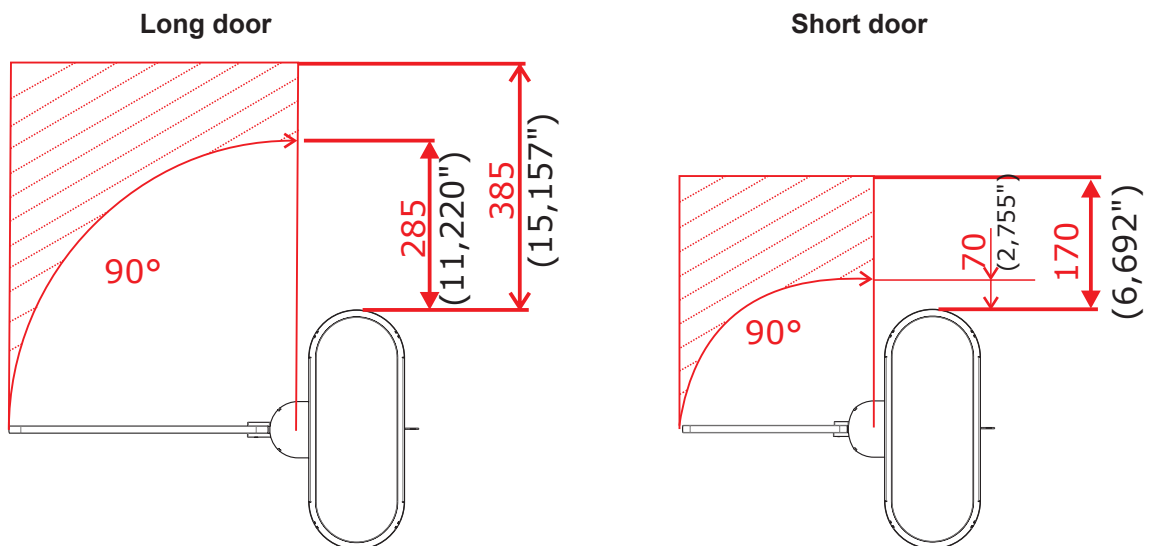

#### e) Card retention time in the reader:

**Selection:** DS2-P6 Configures how long the card placed in the reader should remain available for reading before being permanently withdrawn.

**b) Accumulation of validations (Access queue):**

**Selection:** DS2-P3 With this functionality, multiple consecutive releases can be counted so that a queue of users can proceed continuously without the door closing. For this to be recognized, the next person in line must trigger the release while the first person is passing (before the door starts closing).

**c) Speed of door movement**

**Selection:** DS2-P4 Allows configuring the speed of the doors during the opening and closing cycles. The slow movement speed corresponds to 30% of the equipment's nominal speed.

**d) Safe mode:**

**Selection:** **DS2-P5** With this configuration enabled, the equipment's doors remain open while the user is obstructing the sensors present in the equipment. Additionally, during the door-closing process, if the sensors or doors are obstructed, they reopen and will only close again after the time pre-configured on switches DS2-P1 and DS2-P2. When this function is disabled, the doors close even if the user is obstructing the sensors, forcing users to clear the passageway.



**f) Passage confirmation configuration:**

**Selection:** DS2-P7 (Configuration available only in clips) Allows confirmation of a user's passage through the passageway. To identify this event, the equipment generates a slight door movement (invitation) and waits for the user to signal their intention to pass by gently pushing the door. Upon identifying the passage, the equipment generates the confirmation according to the DS2-P7 configuration, which can be: Confirmation of passage by pulse or confirmation of passage by disk emulation.

**g) Operating mode:**

**Selection:** DS2-P8 Selects the operating mode of the equipment, which are: dTower mode, where the sensors track the user throughout the passage; clip mode, which operates without the aid of sensors for passage control and relies solely on the passage timeout for door closure.

## 7. Technical specifications

### 7.1 Dimensions

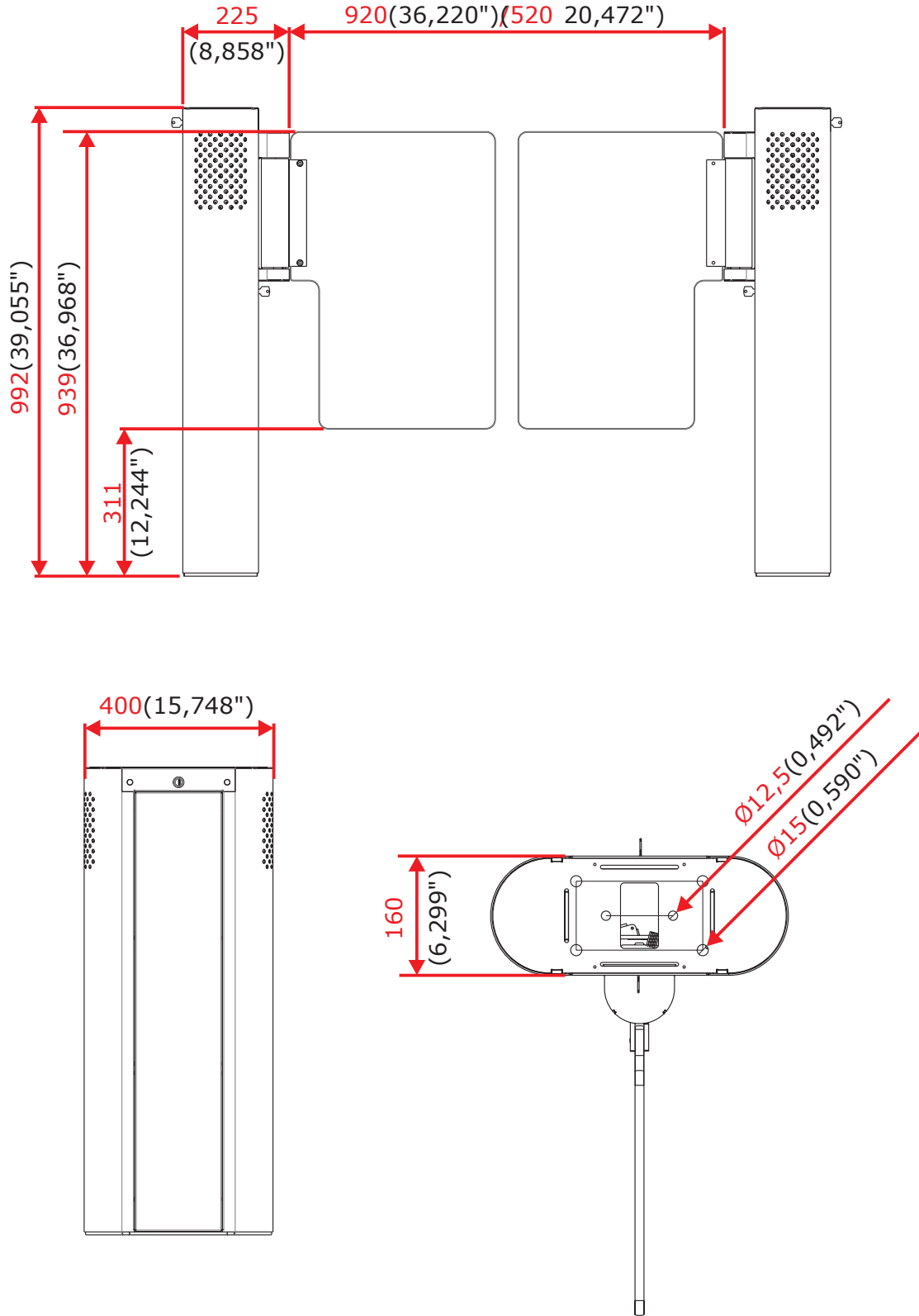

## 7.2 Other Information

Technical Data	Features
Power Supply (Internal Source)	100 - 240 VCA; 4,6 - 3,3 A
Power Supply (External Source)	24 VCC 5A ( +/-5%) ( One power supply per module)
Frequency	50/60 Hz
Average door open/close time	As configured
Operating temperature	0 °C e 50 °C
Approximate weight	100kg per packaged module

Consumption	
Standby	53 W
Peak during passage	73 W

## 8. Troubleshooting

FAULT	POSSIBLE CAUSES	ACTION
dTower R does not turn on.	External AC power supply dTower R	Check if the AC power supply wiring is in accordance with the item: (Reference in the AC electrical connection manual, cable 037.12.253).
	Internal DC power supply dTower R.	Check the status LEDs of the power supply on the dTower R interconnection board.
		Check connectors CN1 and CN2 on the dTower R interconnection board.
dTower T does not turn on.	External AC power supply dTower T	Check if the interconnection cables are properly connected and comply with the items: (References for signal and AC power electrical connections in the manual).
	Internal DC power supply dTower R	Check the power status LEDs on the dTower T interconnection board.
		Check the CN6 connection cable between dTower R and T.
When turning on the dTower, the circuit breaker immediately turns off.	AC power grid short circuit	Remove the interconnection to isolate dTower T and review whether the Phase, Neutral, and Ground lines are connected to the correct locations and comply with the items: (References for AC power supply connections).
Intermittent sound alert and side and top pictograms in red without obstruction in the barrier.	Misalignment of emitter and receiver sensors	Check the alignment of dTower R and T.
	Power supply and sensor signals dTower R	Check the connection between the cable and connector CN16 on the
	Power supply for dTower T sensors	Check the connection between the cable and connector CN10 on the interconnection board.

Side and top pictograms in red.	Communication failure between the controller board and the control board of the controller.	Addressing control board Motor dTower R addressing. SW1-01 ON SW1-02 ON SW1-03 ON SW1-04 ON
		Addressing control board of motor dTower T. SW1-01 ON SW1-02 OFF SW1-03 OFF SW1-04 ON
		Check the connection of the connectors CN10 control board, CN3 and CN9 motor interconnection board and CN1 motor control board.
dTower doors do not move.	Power failure on the motor board.	Verify the connections of the CN9 connectors on the interconnection board and CN1 on the motor control board.
	Power failure on the motor board.	Connections between the motor and the motor control board.
Mechanical brake dTower door.	Connection of the brake activation cable.	Check the brake coil cable connection with CN3 on the motor control board.
	Dip Switch motor control board.	SW1-01 must be ON
dTower doors misaligned.	Door calibration.	Turn off the motor control board by removing the power and communication cable from connector CN1. Remove the Hall sensor cable from CN4 and insert the connector CN1. Wait for the initialization to complete, indicated by LD1 switching between green and red. Turn off the board again by removing connector CN1, insert connector CN4, and power it on again through connector CN1 to allow it to perform the automatic calibration process. At this moment, the door must be unobstructed; it will move to the end stops, clockwise and counterclockwise, and then center itself.

Side pictograms of dTower R turned off.	Control or power cable disconnected.	Check the connection of the CN12 and CN13 connectors on the dTower control board. Check the CN3 and CN8 connectors on the dTower R interconnection board. Check the connection of the CN1 connector on the lateral pictogram dTower.
		Check the 5V status LED on the dTower interconnection board.
Side pictograms of dTower T off.	Control or power cable disconnected.	Check the connection of connectors CN12 and CN13 on the dTower control board. Check connectors CN4 and CN8 on the dTower R and T interconnection boards. Check the connection of CN1 on the dTower side pictogram board.
		Check the 5V status LED on the dTower interconnection board.
Top pictograms of dTower R off.	Control or power cable disconnected.	Check the connection of connector CN3 on the dTower control board. Check the connectors CN3 and CN8 on the dTower interconnection board. Check the connection of CN1 on the board.
		Check the 5V status LED on the dTower interconnection board.
Top pictograms of dTower T off.	Control or power cable disconnected.	Check the connection of the CN3 connector on the dTower control board. Verify the connectors CN4 and CN8 on the dTower R and T interconnection boards. Check the CN1 connection on the upper pictogram dTower.
		Check the 5V status LED on the dTower interconnection board.

## **9. Preventive Maintenance**

For the estimation of preventive maintenance times, it was assumed 1600 passages/day and 30 days/month. Since these are reference values, they may change depending on the customer's usage mode, and the customer should make the necessary adjustments to obtain the new times.

### **Calculation base:**

**Passage cycle:** 1600 (Estimated passages in one day).

**Month (days):** 30

### **Cycles in a month: 48,000**

<b>Cycles</b>	<b>Month of Maintenance</b>
300,000	6 months
500,000	10 months
1 million	22 months
1.5 million	32 months

### **9.1 Preventive Actions Table:**

<b>Action</b>	<b>Frequency</b>
Calibrate the doors.	1x / 3 months
Analyze the operation of the doors, aiming to identify any noises, heavy mechanisms, and abnormal activations.	1x / 6 months
Analyze the activation of the upper LEDs of the equipment.	1x / 6 months
Analyze the activation of the entry and exit pictogram.	1x / 6 months
Analyze the buzzer activation through validations and invalid entries.	1x / 6 months
Check the 24V output on the power supplies that feed the motor.	1x / 6 months
Check the operation of the mechanical brake of the doors.	1x / 6 months
Check the operation of the biometric reader(s)..	1x / 6 months
Check the operation of the contactless card reader(s).	1x / 6 months
Check the tightening of the door mounting screws.	1x / 6 months
Check the functioning of the bearings.	1x / 10 months
Visually inspect the keys.	1x / 6 months
Check the motor operation.	1x / 22 months
Check the condition of the doors visually.	1x / 6 months
Check the operation of the locks.	1x / 22 months





## **10. Cleaning**

### **10.1 Maintenance and conservation of stainless steel:**

Do not use chemical products, bleach, or household cleaning products.

**Routine cleaning:** The best products for maintaining stainless steel are water, soap, mild and neutral detergents, and ammonia-based cleaners diluted in warm water, applied with a soft cloth or a nylon sponge. Afterward, rinse thoroughly with plenty of water, preferably warm, and dry with a soft cloth.

**Fat, Oils, and Grease:** Clean thick deposits with a soft cloth or paper towel. Then, apply a warm solution of detergent or ammonia. Afterward, follow the routine cleaning procedures.

**Fingerprints:** Remove with a soft cloth or paper towel dampened with isopropyl alcohol (available in compounding pharmacies) or an organic solvent (ether, benzine).

**Labels, stickers, or films:** Peel off as much as you can. Apply warm water to the surface and scrub with a soft cloth. If the adhesive persists, dry it and gently rub with alcohol or an organic solvent. But be careful: never scrape the stainless steel surface with blades, spatulas, or coarse abrasives.

**Manchas de ferrugem:** With a cotton swab soaked in water and 10% nitric acid, apply topically, keeping the area moist for 20 to 30 minutes, repeating the operation if necessary.

More stubborn stains will require vigorously rubbing the stained surface with a paste made of fine household abrasive (scouring powder), water, and 10% nitric acid, using a polishing pad. The acid treatment should always be followed by rinsing with an ammonia or baking soda solution and routine cleaning.

**Moderate dirt / light stains:** When routine cleaning is not enough, apply a mixture made with plaster or baking soda, dissolving it with household alcohol until a paste is formed. Use a soft cloth or a nylon pad to apply this mixture to the stainless steel surface. If preferred, you can also use a soft-bristle brush, being careful not to scrub; do so as gently as possible, making long, even strokes in the direction of the polished finish, if applicable. Avoid scrubbing in circular motions. Then simply rinse with plenty of water, preferably warm, and dry with a soft cloth.

**Intense dirt / pronounced stains:** Apply warm or hot detergent, or a solution of an ammonia-based remover (household removers) and water. If this is not enough to soften burned food or charred deposits, use more aggressive products, such as caustic soda-based cleaners used in household cleaning.

## 10.2 Maintenance and conservation of polycarbonate (doors):

### Routine cleaning:

- Choose a dry day with preferably low humidity, as soot that may have accumulated on the door will be easier to remove. If possible, remove the polycarbonate item (door) for easier cleaning handling.
- Moisten the polycarbonate doors with water until the excess dirt detaches. The persistence in using water is essential because if you wipe over the soot's grain, you would be sanding the polycarbonate instead of cleaning it. The result would be a hazy and dull (matte) door.
- Prepare a 100% cotton cloth and a mild detergent from a reputable brand. Do not use regular brooms, as they will scratch the polycarbonate.
- Mix the mild detergent with water in a bucket to create ample foam, then gently apply the solution with the cloth in a single direction, following the water's flow. Never wipe in circular motions. Rinse thoroughly and repeat the process until satisfactory results are achieved.
- Avoid letting the sun dry the solution on the polycarbonate, as this may cause stains.
- **Paint splashes on polycarbonate:** It is common, when painting walls, for latex paint splashes to appear on the polycarbonate panel. Do not use solvents such as thinner, gasoline, benzene, or acetone. Isopropyl alcohol or kerosene can solve the problem. Try to clean it before the paint dries and wash the area with the water and mild detergent solution.

**Polycarbonate Cleaning Frequency:** There is no set period for cleaning. The amount of soot dispersed in the air, generated by dirt roads, factories, and construction in the area, may require more frequent cleaning. Start with a monthly cleaning and evaluate. Then, adjust this interval to a more convenient one. Clean without scratching.

 **ATTENTION!** - Even for more stubborn dirt, try starting the cleaning process with the gentlest method. Be patient and repeat the operation a reasonable number of times before resorting to harsher cleaning methods.

## 11. Warranty and Technical Support

Digicon is responsible for the design, high-quality craftsmanship, and materials used in the manufacturing of its products, ensuring that the equipment and all its parts are free from defects or flaws in material and workmanship. Digicon is committed to replacing or repairing any part or equipment that presents manufacturing defects at no cost to the buyer, under the conditions stipulated below:

1. *The buyer is responsible for the transportation costs to and from the product's location.*
2. *The warranty period starts from the issuance date of the sales invoice and covers: 12 (twelve) months for equipment, accessories, parts, and components, including the legal warranty period of 90 (ninety) days.*

### **Legal Warranty:**

*"The consumer has a period of 90 (ninety) days, starting from the date of issuance of the purchase invoice, to report apparent irregularities (defects) that are easily and immediately noticeable in the product, such as items constituting the external parts and any other accessible to the user, as well as appearance parts and general accessories."*

- The warranty will be provided to the buyer only upon presentation of an invoice (original or copy). Service is carried out upon request through the following emails:
- **Access Control and Timekeeping Area:** [sac.vca@digicon.com.br](mailto:sac.vca@digicon.com.br)
- **Urban Mobility Area:** [sac.mobilidadeurbana@digicon.com.br](mailto:sac.mobilidadeurbana@digicon.com.br)
- **Information required to open a support ticket:**

Company Name:
Tax Identification Number (TIN)
Full Address:
Responsible Person's Name:
Contact Phone Number:
Model(s) of the faulty equipment:
Serial number(s) of the faulty equipment:
Fault(s) presented:

## **12. Important Information**

- The Digicon reserves the right to modify the characteristics of its products at any time to adapt them to the latest technological developments.

- Digicon reserves the right to change the information contained in this manual without prior notice.

- “After the product’s useful life, dispose of it according to the National Waste Policy.”

The disposal should not be in regular waste, as it may cause harm to the environment and human health.

You can send it to one of our addresses in Gravataí/RS or Barueri/SP or take it to a local recycling collection point in your area.

**NOTES:**

Headquarters/RS

Development, Factory, Technical Assistance, and Sales  
Rua Nissin Castiel, 640 - Distrito Industrial  
Gravataí/RS CEP 94045-420  
E-mail: vendas.aceso@digicon.com.br

Home page: [www.digicon.com.br](http://www.digicon.com.br)